

# LAMPIRAN

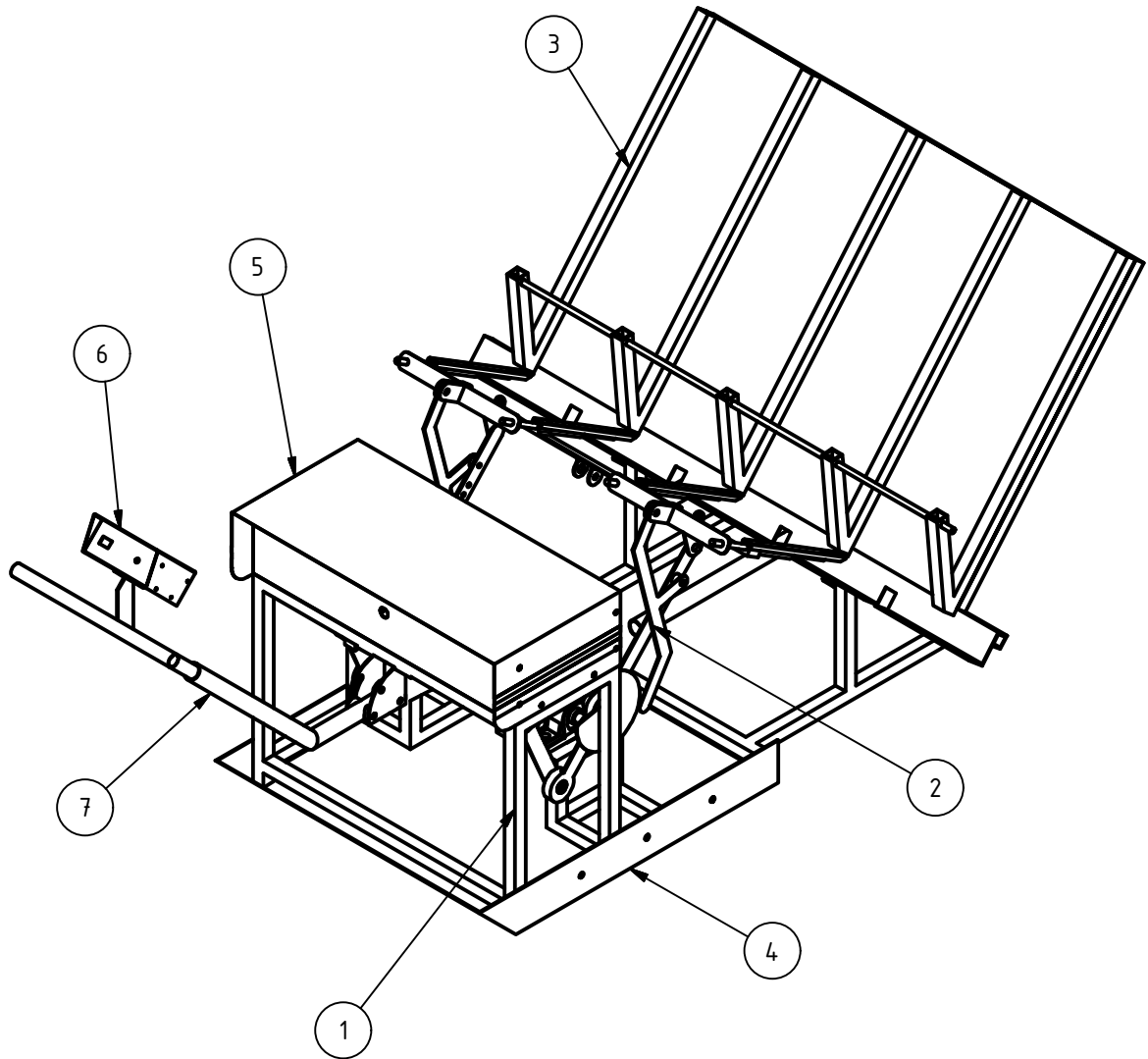

## PARTS LIST

ITEM	QTY	PART NUMBER	DESCRIPTION
1	1	Rangka	
2	1	Lengan Penanam	
3	1	Meja Penampung	
4	1	Pelampung	
5	1	Kotak Panel	
6	1	Kotak Control	
7	1	Handle	

## Mesin Tanam Padi Elektrik

Skala :	Digambar		Tim
1 : 10	Diperiksa		
	Waktu		
	Dilihat		

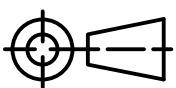

TEKNIK MESIN FT UNY

Kelompok 9

A4

1

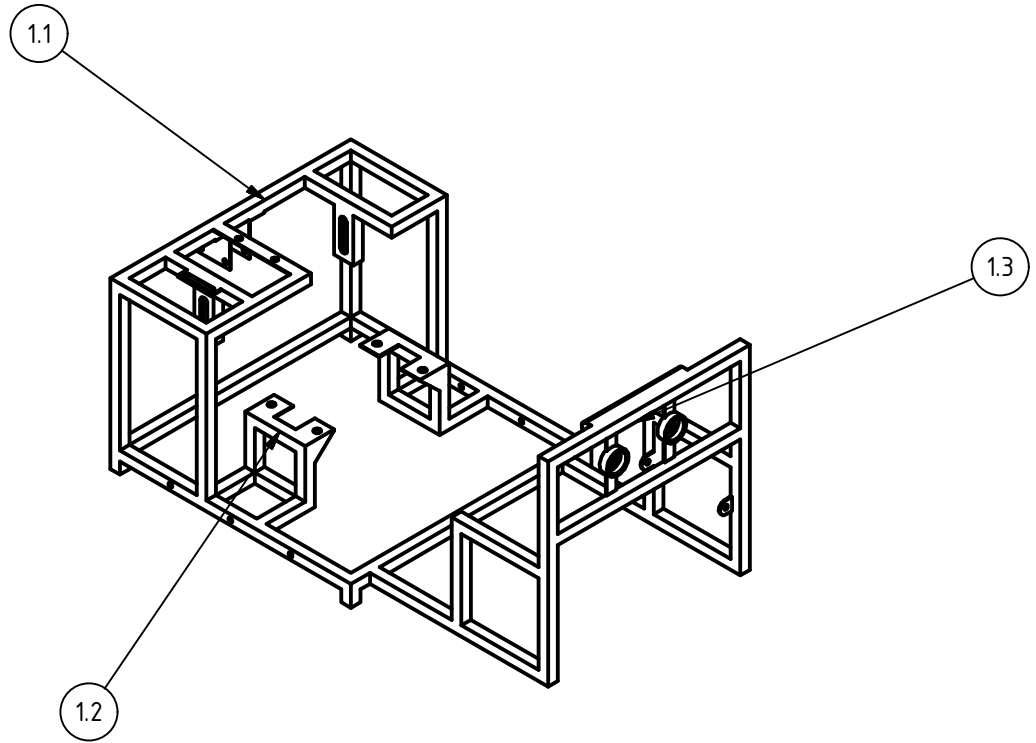

PARTS LIST

ITEM	QTY	PART NUMBER	DESCRIPTION
1.1	1	Rangka dudukan motor	
1.2	1	Rangka dudukan lengan penanam	
1.3	1	Rangka dudukan meja penampung bibit	

Mesin tanam padi elektrik

Skala :	Digambar	10-10-18	T i m
0,09:1	Diperiksa		
	Waktu		
	Dilihat		

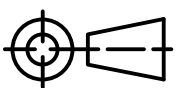

TEKNIK MESIN FT UNY

Kelompok 9

A4

1

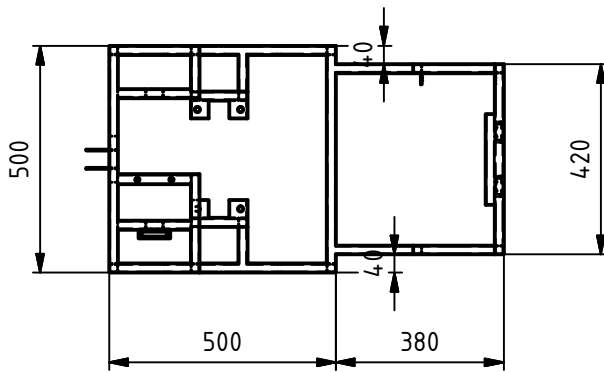
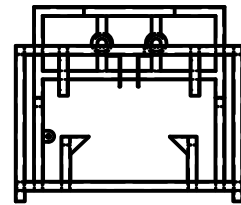
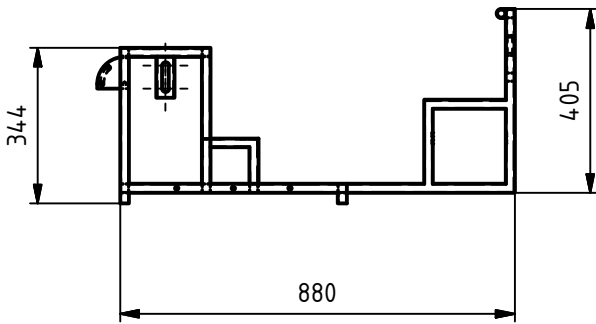
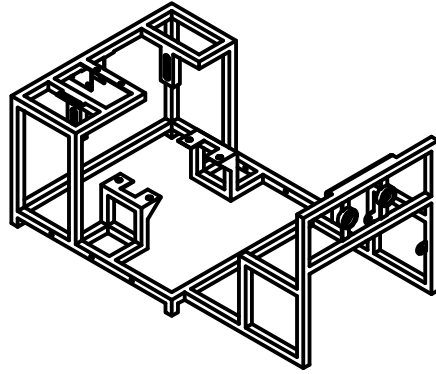

PARTS LIST

ITEM	QTY	PART NUMBER	DESCRIPTION
1	1	Rangka	

Mesin tanam padi elektrik

Skala : 0,06:1	Digambar	10-10-18	T i m
	Diperiksa		
	Waktu		
	Dilihat		

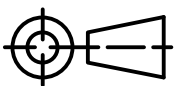

TEKNIK MESIN FT UNY

Kelompok 9

A4

1

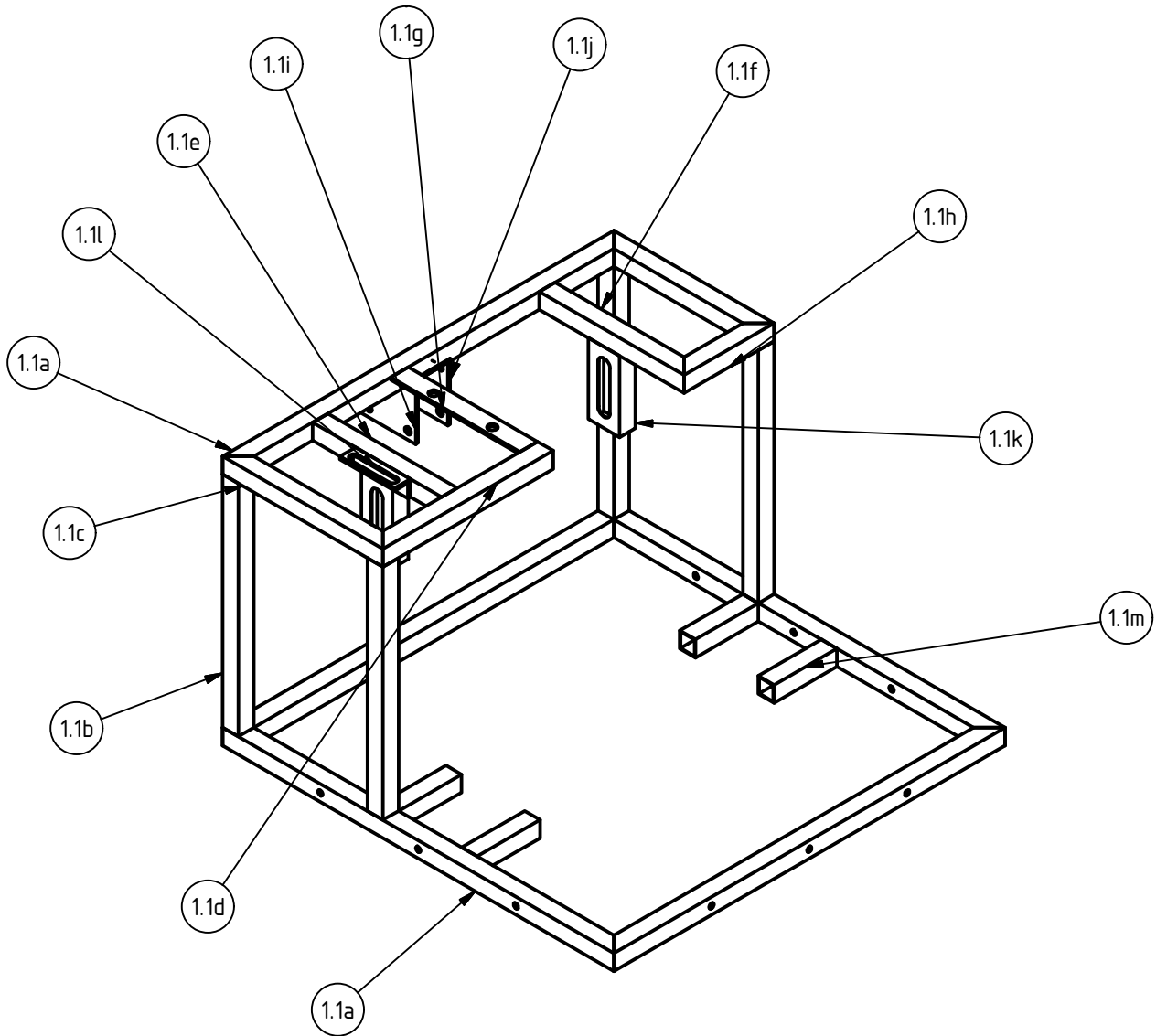

PARTS LIST

ITEM	QTY	PART NUMBER	DESCRIPTION
1.1	1	Rangka dudukan motor	

Mesin tanam padi elektrik

Skala :	Digambar	10-10-18	T i m
0.16:1	Diperiksa		
	Waktu		
	Dilihat		

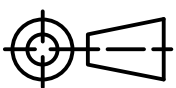

TEKNIK MESIN FT UNY

Kelompok 9

A4

1

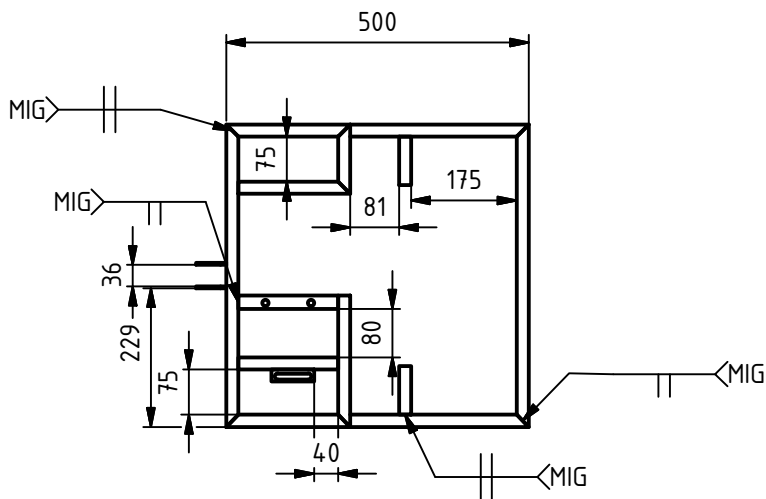
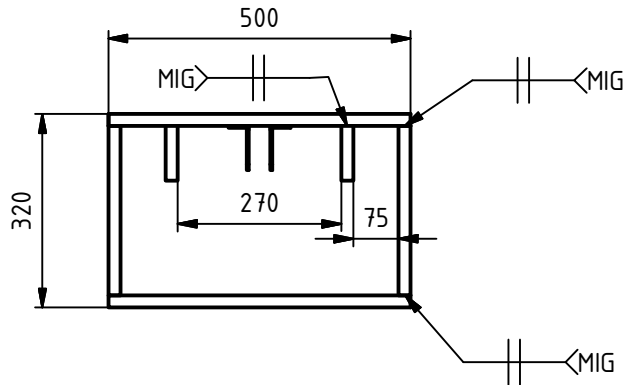
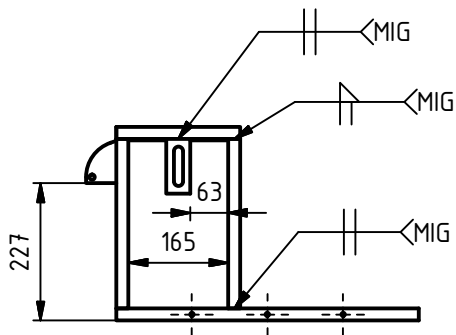
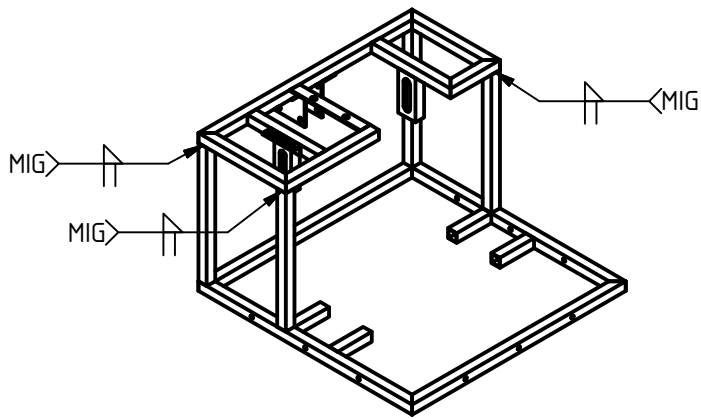

PARTS LIST

ITEM	QTY	PART NUMBER	DESCRIPTION
1.1	1	Rangka dudukan motor	

Mesin tanam padi elektrik

Skala :	Digambar	10-10-18	T i m
0.08:1	Diperiksa		
	Waktu		
	Dilihat		

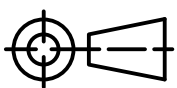

TEKNIK MESIN FT UNY

Kelompok 9

A4

1

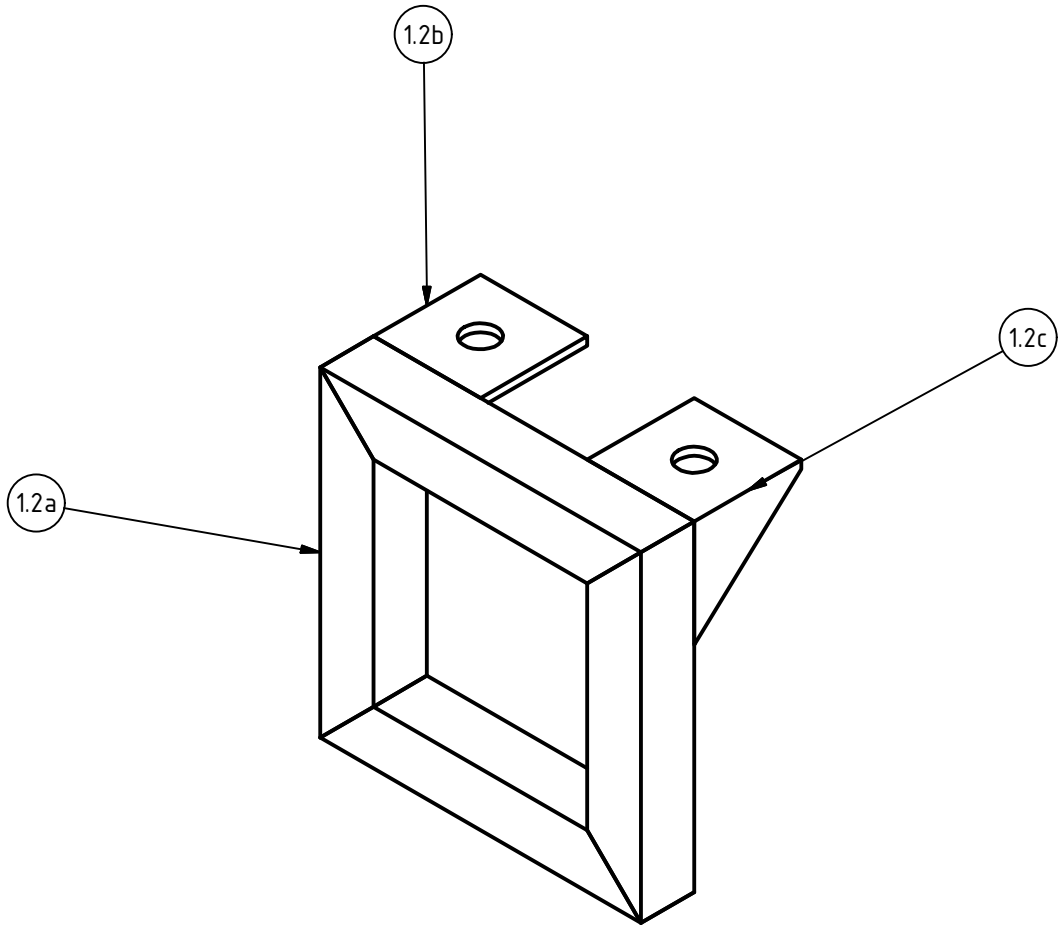

PARTS LIST

ITEM	QTY	PART NUMBER	DESCRIPTION
1.2	1		Rangka dudukan lengan penanam

Mesin tanam padi elektrik	Skala :	Digambar	10-10-18	T i m
	1:3	Diperiksa		
		Waktu		
		Dilihat		

	TEKNIK MESIN FT UNY	Kelompok 9	A4
--	---------------------	------------	----

1

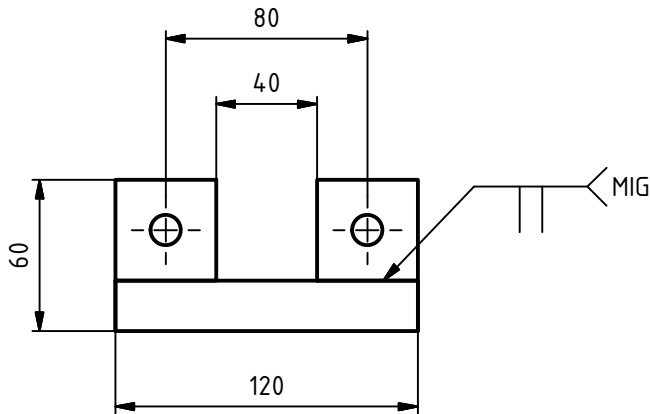
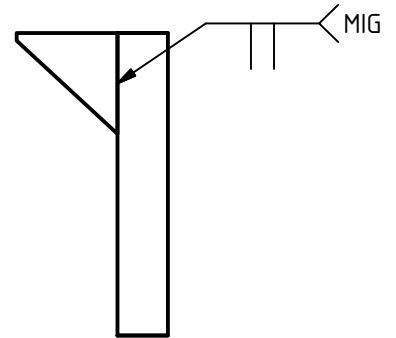
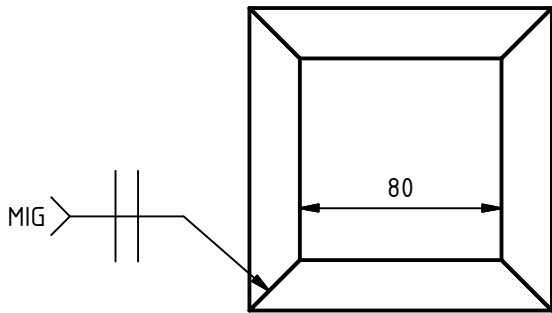
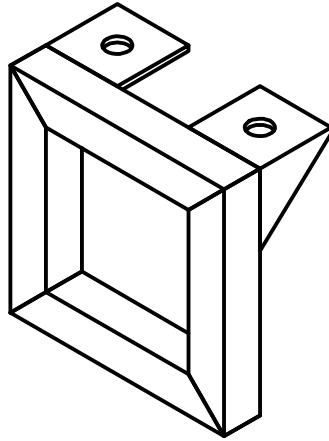

PARTS LIST

ITEM	QTY	PART NUMBER	DESCRIPTION
1.2	1		Rangka dudukan lengan penanam

Mesin tanam padi elektrik

Skala :	Digambar	10-10-18	T i m
1:3	Diperiksa		
	Waktu		
	Dilihat		

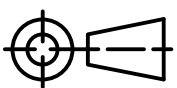

TEKNIK MESIN FT UNY

Kelompok 9

A4



1.3

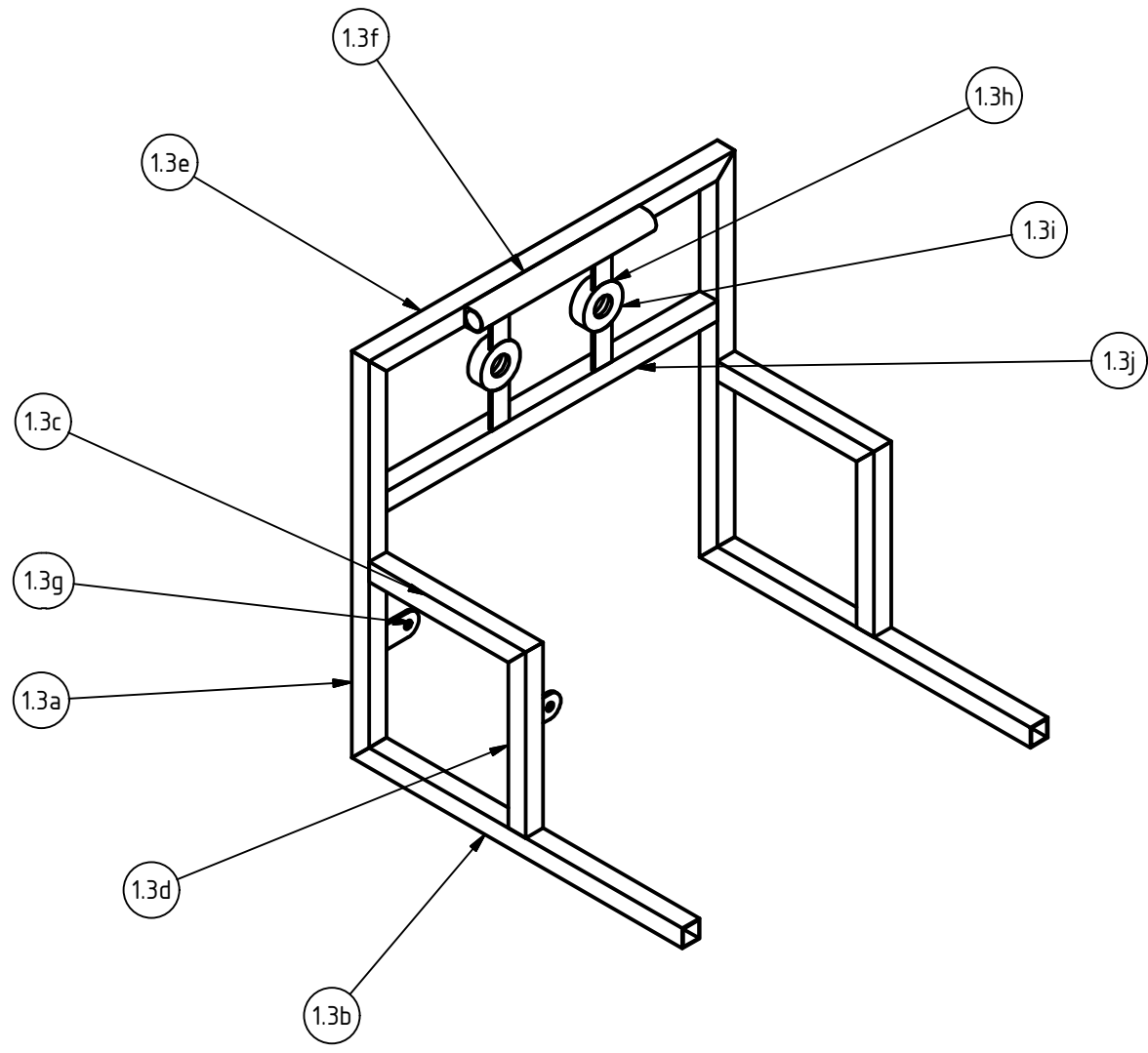

PARTS LIST

ITEM	QTY	PART NUMBER	DESCRIPTION
1.3	1		Rangka dudukan meja penampung bibit padi

Mesin tanam padi elektrik

Skala :	Digambar	10-10-18	T i m
1 : 8	Diperiksa		
	Waktu		
	Dilihat		

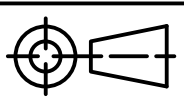

TEKNIK MESIN FT UNY

Kelompok 9

A4

1.3

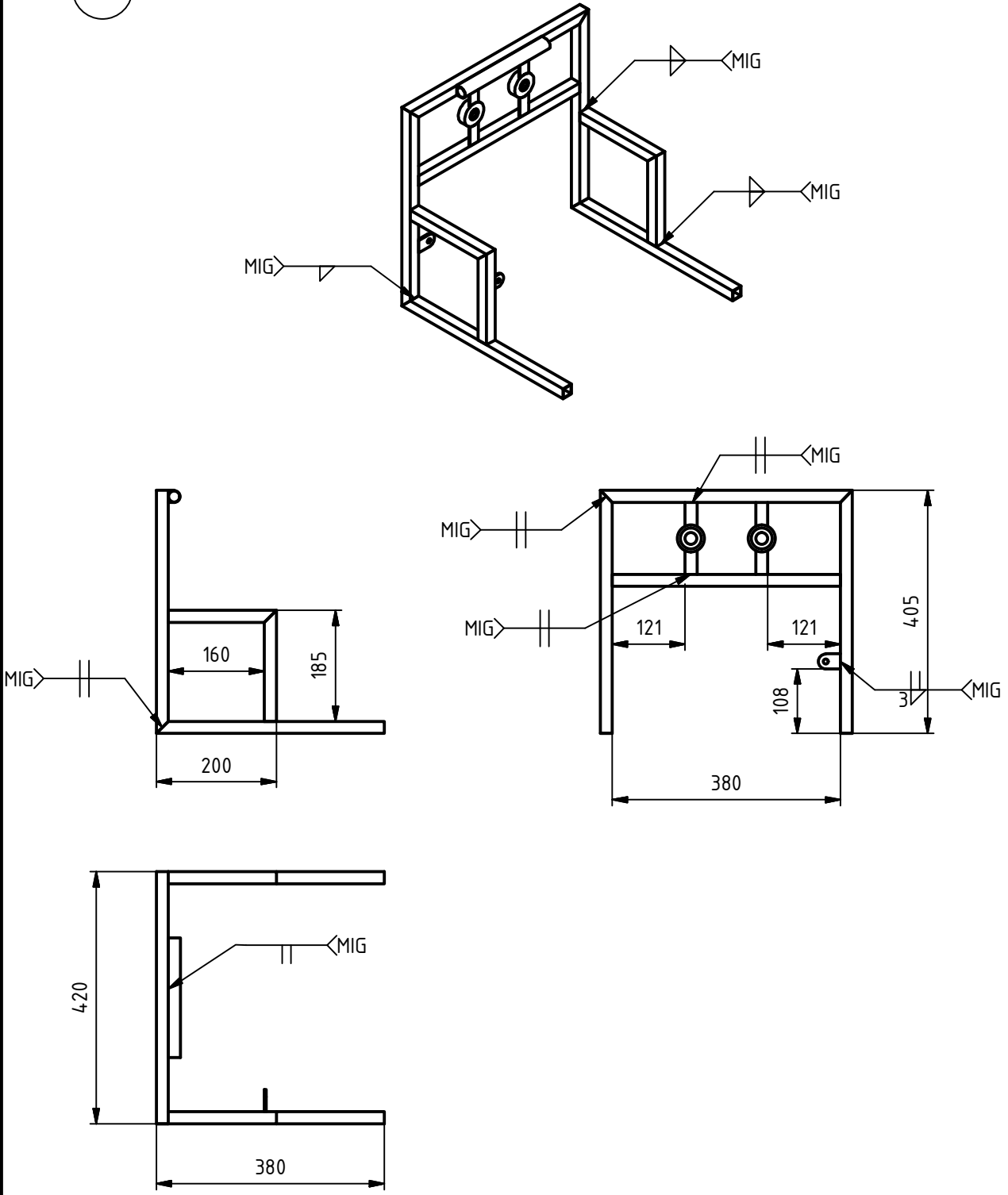

PARTS LIST

ITEM	QTY	PART NUMBER	DESCRIPTION
1.3	1		Rangka dudukan meja penampung bibit padi

Mesin tanam padi elektrik

Skala :	Digambar	10-10-18	T i m
1 : 8	Diperiksa		
	Waktu		
	Dilihat		

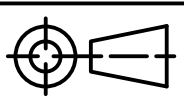

TEKNIK MESIN FT UNY

Kelompok 9

A4

1.1a jumlah: 5  
skala 1:4

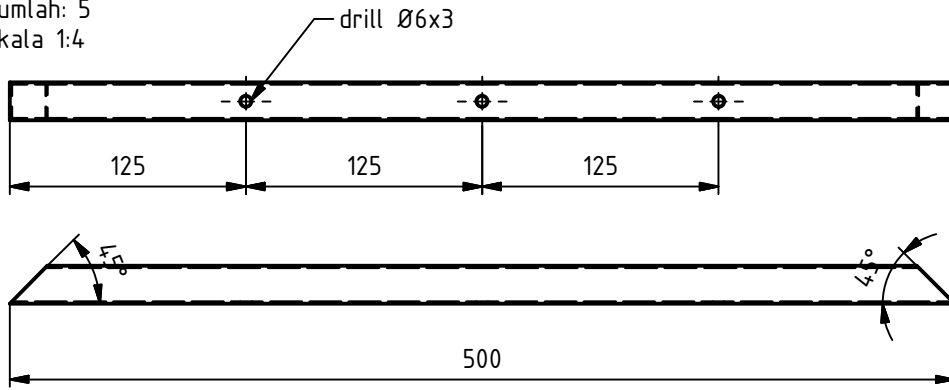

1.1b jumlah: 4  
skala 1:4

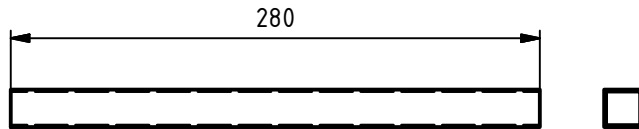

1.1c jumlah: 2  
skala 1:3

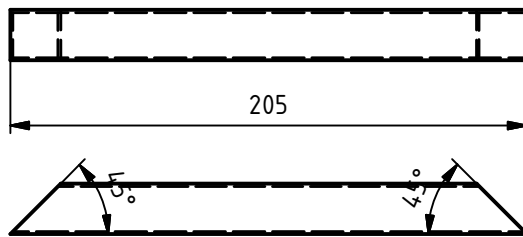

1.1e jumlah: 1  
skala 1:3

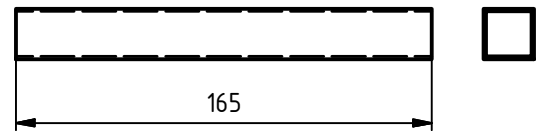

1.1f jumlah: 1  
skala 1:3

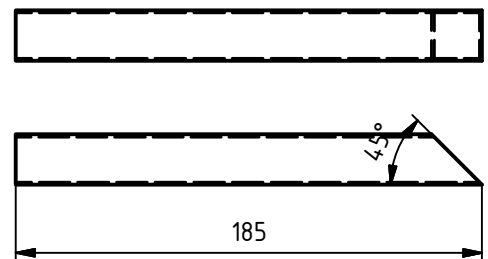

1.1d jumlah: 1  
skala 1:3

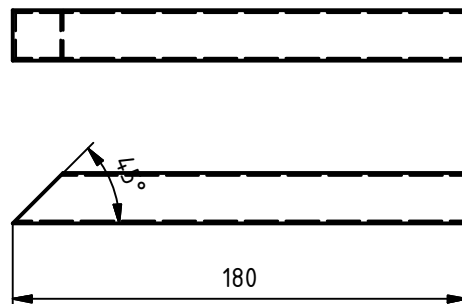

PARTS LIST

ITEM	QTY	PART NUMBER	DESCRIPTION
1.1	1	Rangka dudukan motor	hollow 20x20x1,4

Mesin tanam padi elektrik

Skala :	Digambar	10-10-18	T i m
	on part	Diperiksa	
		Waktu	
		Dilihat	

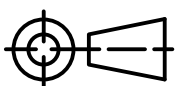

TEKNIK MESIN FT UNY

Kelompok 9

A4

1.1g jumlah 2  
skala 1:2

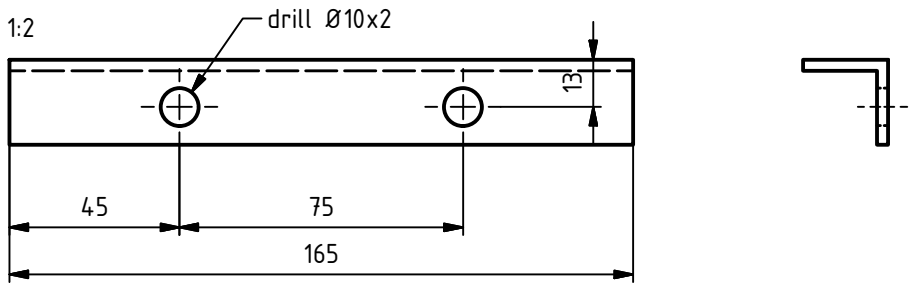

1.1h jumlah 1  
skala 1:2

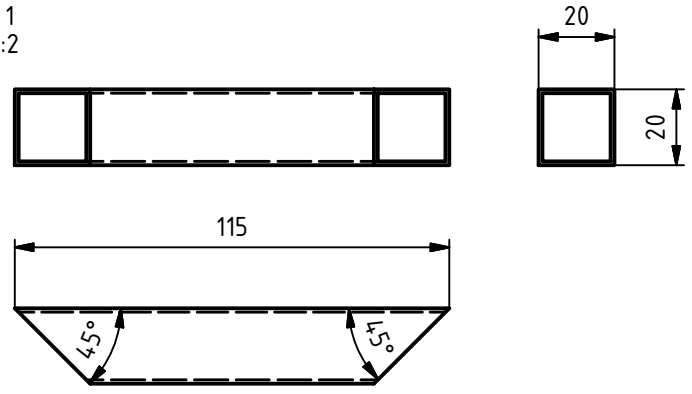

1.1l jumlah 1  
skala 1:1

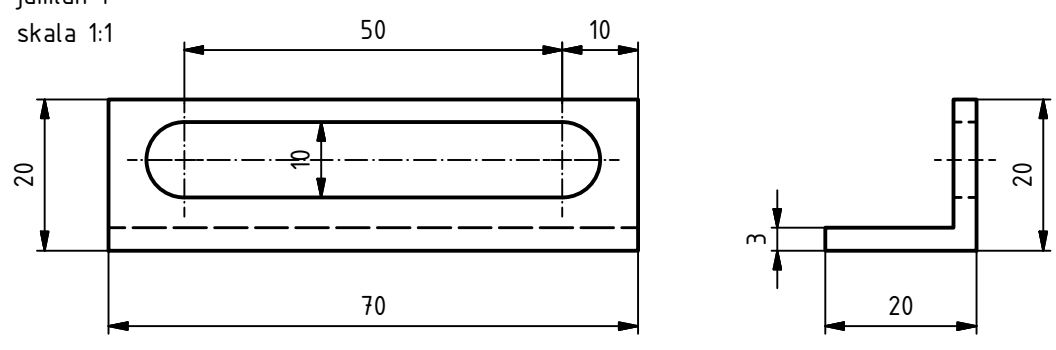

1.1m jumlah 4  
skala 1:2

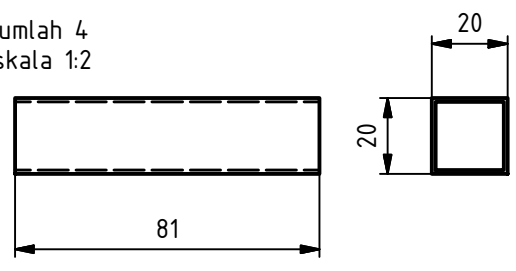

PARTS LIST

ITEM	QTY	PART NUMBER	DESCRIPTION
1.1	1	Rangka dudukan motor	

Mesin tanam padi elektrik

Skala :	Digambar	10-10-18	T i m
	on part	Diperiksa	
		Waktu	
		Dilihat	

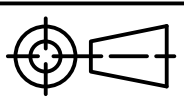

TEKNIK MESIN FT UNY

Kelompok 9

A4

1.1k jumlah 2

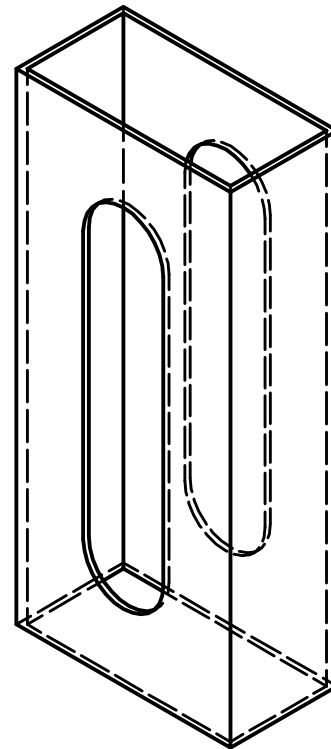
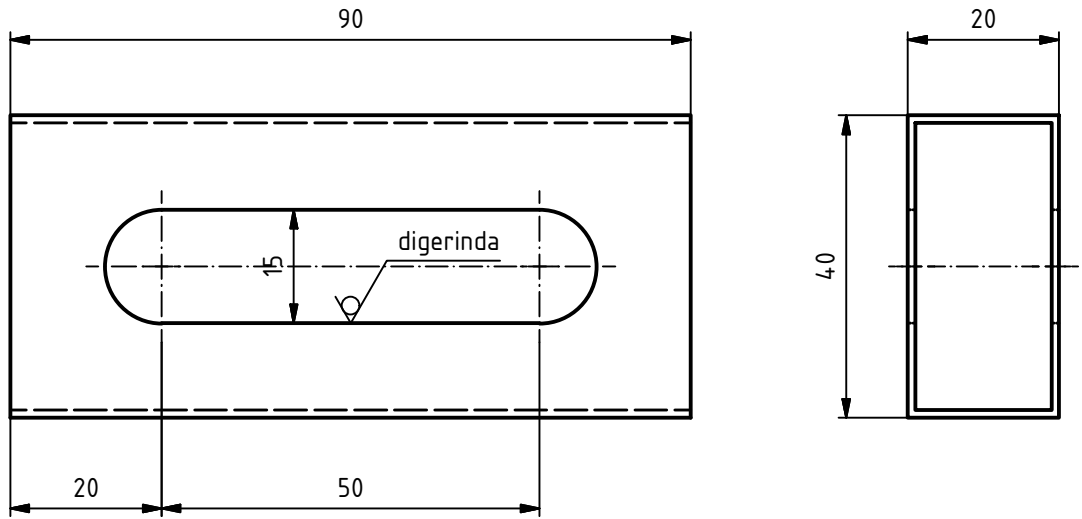

PARTS LIST

ITEM	QTY	PART NUMBER	DESCRIPTION
1.1	1	Rangka dudukan motor	hollow 20x40x1,4

Mesin tanam padi elektrik

Skala :	Digambar	10-10-18	T i m
1:1	Diperiksa		
	Waktu		
	Dilihat		

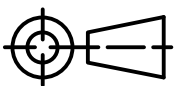

TEKNIK MESIN FT UNY

Kelompok 9

A4

1.1j

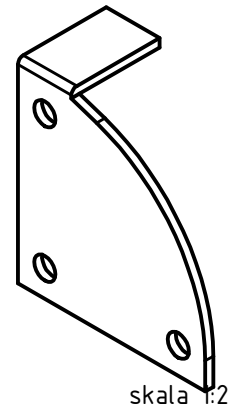
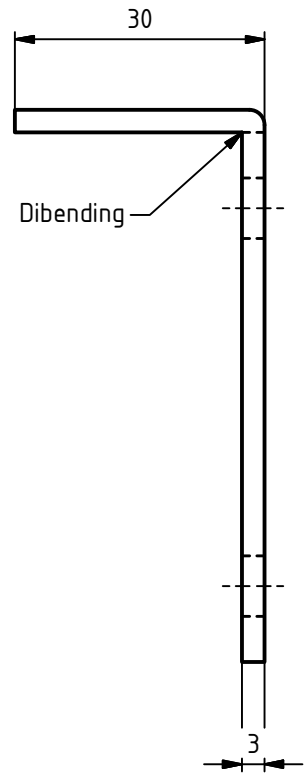
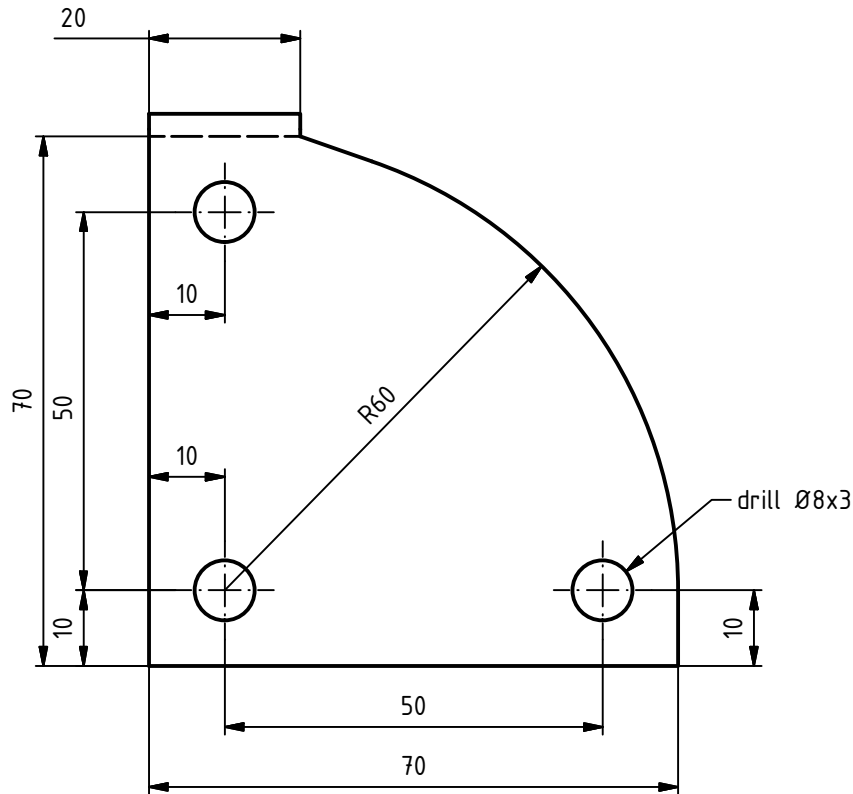

PARTS LIST

ITEM	QTY	PART NUMBER	DESCRIPTION
1.1	1	Rangka dudukan motor	

Mesin tanam padi elektrik

Skala :	Digambar	10-10-18	T i m
1:1	Diperiksa		
	Waktu		
	Dilihat		

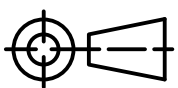

TEKNIK MESIN FT UNY

Kelompok 9

A4

1.2a jumlah 8  
skala 1:2

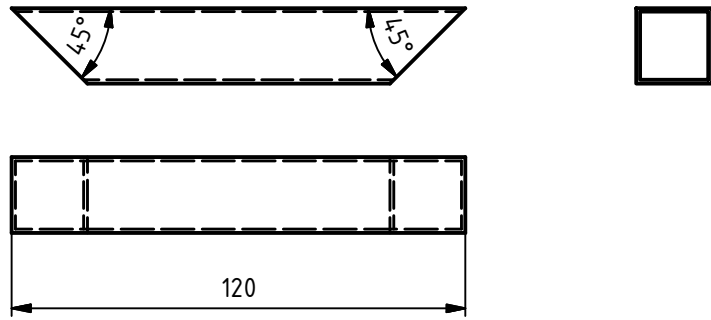

1.2b jumlah 2  
skala 1:1

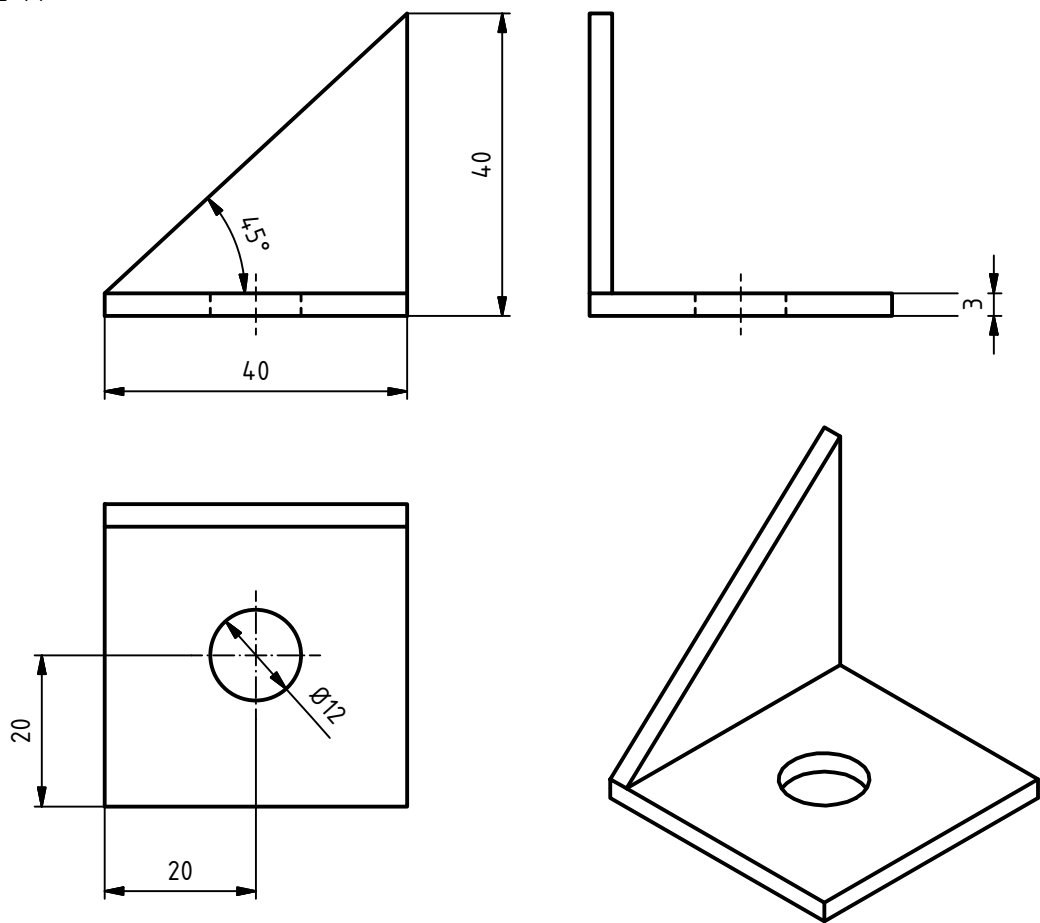

PARTS LIST

ITEM	QTY	PART NUMBER	DESCRIPTION
1.2	1	Rangka dudukan poros lengan penanam	hollow 20x20x1,4 besi siku 40x40x3

Mesin tanam padi elektrik

Skala :	Digambar	10-10-18	T i m
	on part	Diperiksa	
		Waktu	
		Dilihat	

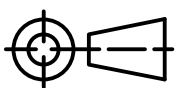

TEKNIK MESIN FT UNY

Kelompok 9

A4

1.2c jumlah 2  
skala 1:1

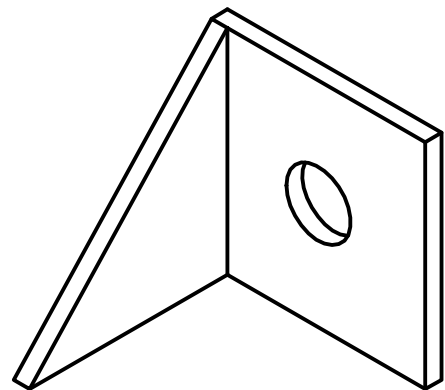
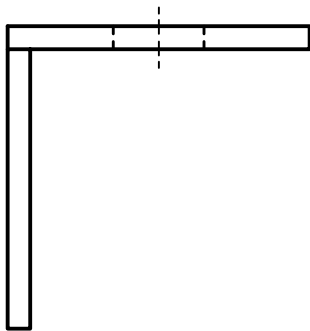
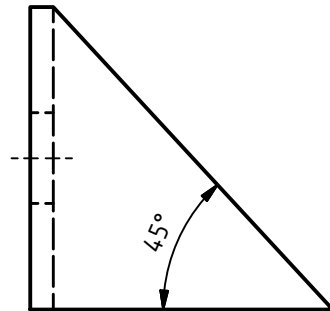
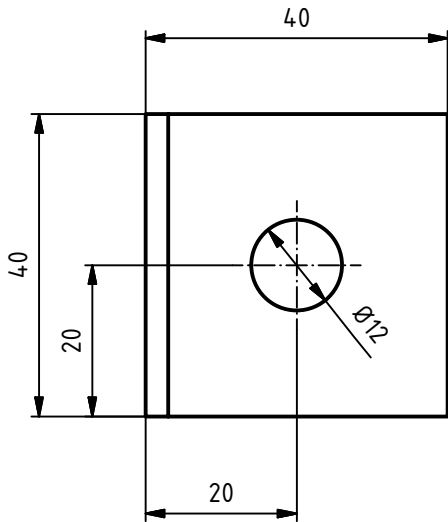

PARTS LIST

ITEM	QTY	PART NUMBER	DESCRIPTION
1.2	1	Rangka dudukan poros lengan penanam	besi siku 40x40x3

Mesin tanam padi elektrik

Skala :	Digambar	10-10-18	T i m
on part	Diperiksa		
	Waktu		
	Dilihat		

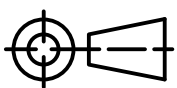

TEKNIK MESIN FT UNY

Kelompok 9

A4



1.3a jumlah 2  
skala 1:4

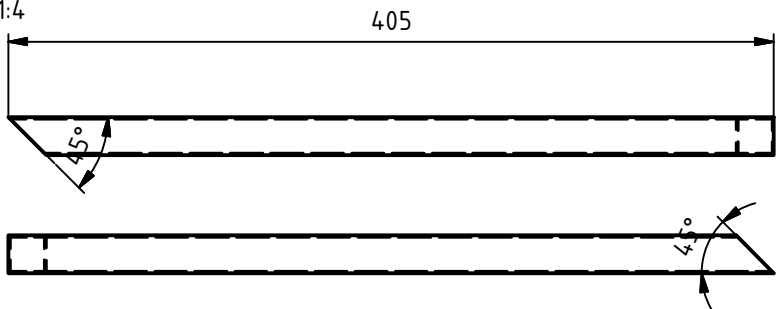

1.3b jumlah 2  
skala 1:4

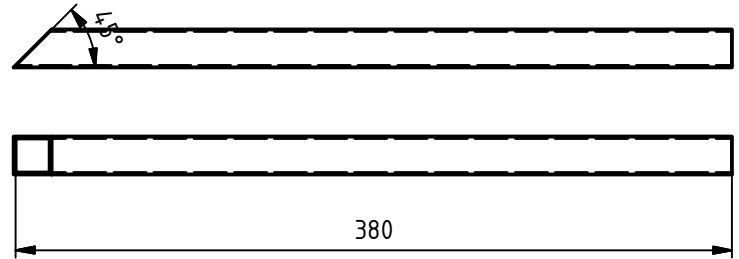

1.3c jumlah 2  
skala 1:2

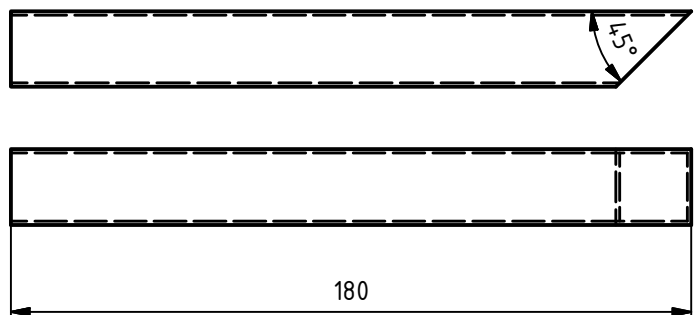

1.3d jumlah 2  
skala 1:2

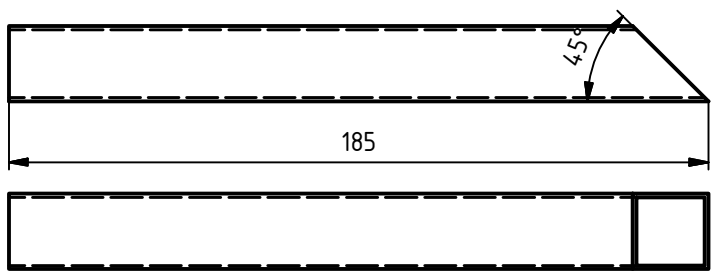

PARTS LIST

ITEM	QTY	PART NUMBER	DESCRIPTION
1.3	1	Rangka dudukan meja penampung bibit padi	hollow 20x20x1,4

Mesin tanam padi elektrik

Skala :	Digambar	10-10-18	T i m
onpart	Diperiksa		
	Waktu		
	Dilihat		

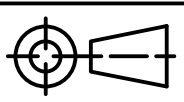

TEKNIK MESIN FT UNY

Kelompok 9

A4

1.3e jumlah 1  
skala 1:4

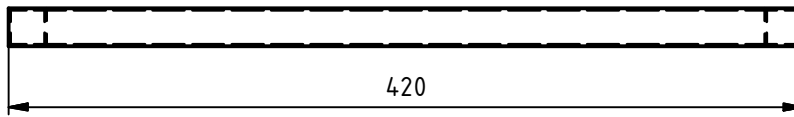
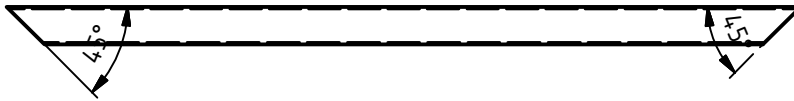

1.3g jumlah 2  
skala 1:1

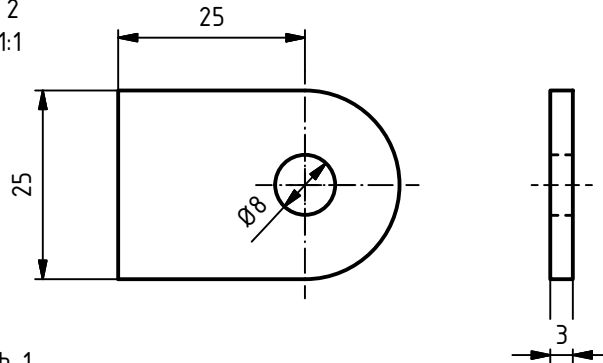

1.3j jumlah 1  
skala 1:4

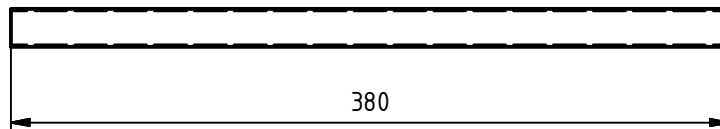

1.3f jumlah 1  
skala 1:2

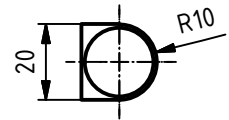
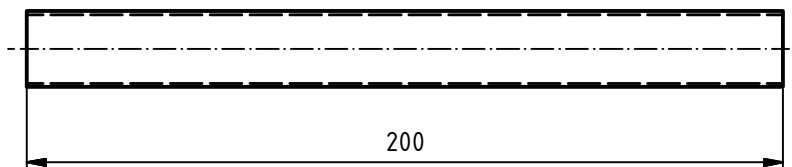

#### PARTS LIST

ITEM	QTY	PART NUMBER	DESCRIPTION
1.3	1		Rangka dudukan meja penampung bibit padi

Mesin tanam padi elektrik

Skala :	Digambar	10-10-18	T i m
1 : 8	Diperiksa		
	Waktu		
	Dilihat		

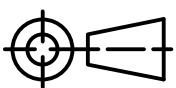

TEKNIK MESIN FT UNY

Kelompok 9

A4

jumlah 2  
skala 1:1

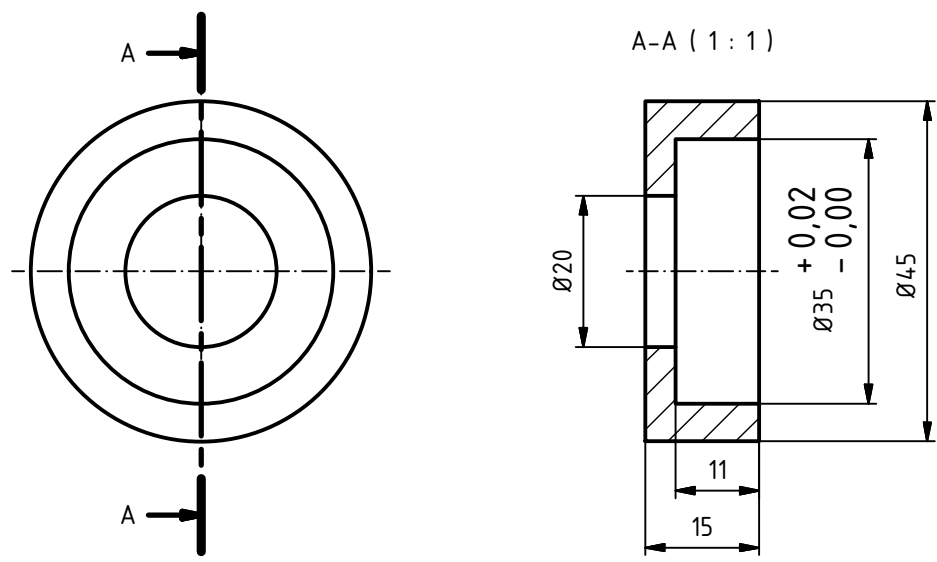

jumlah 4  
skala 2:1

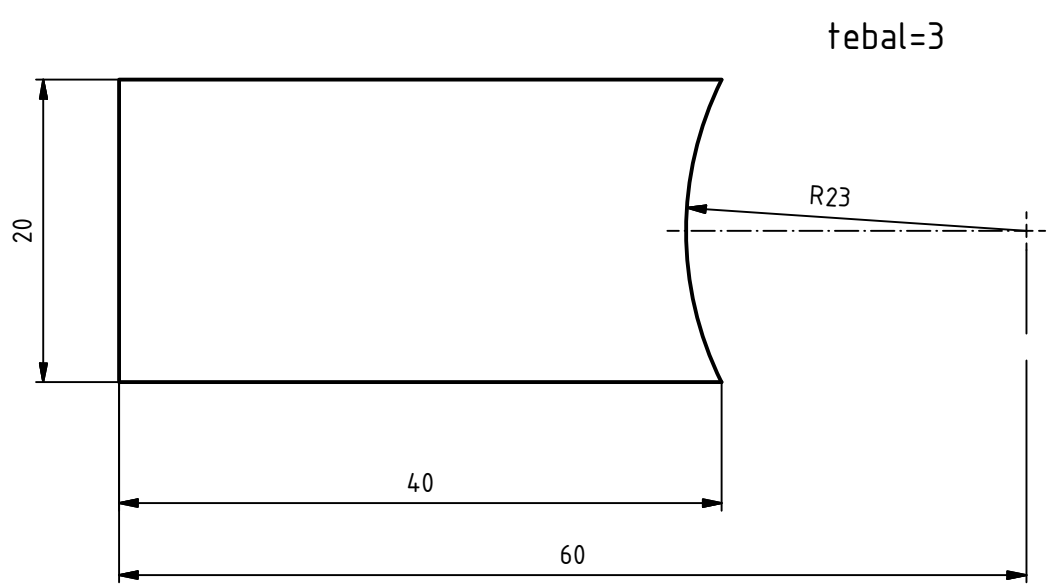

PARTS LIST			
ITEM	QTY	PART NUMBER	DESCRIPTION
1.3	1		Rangka dudukan meja penampung bibit padi

Mesin tanam padi elektrik	Skala :	Digambar	10-10-18	T i m
	1 : 8	Diperiksa		
		Waktu		
		Dilihat		

	TEKNIK MESIN FT UNY	Kelompok 9	A4
--	---------------------	------------	----

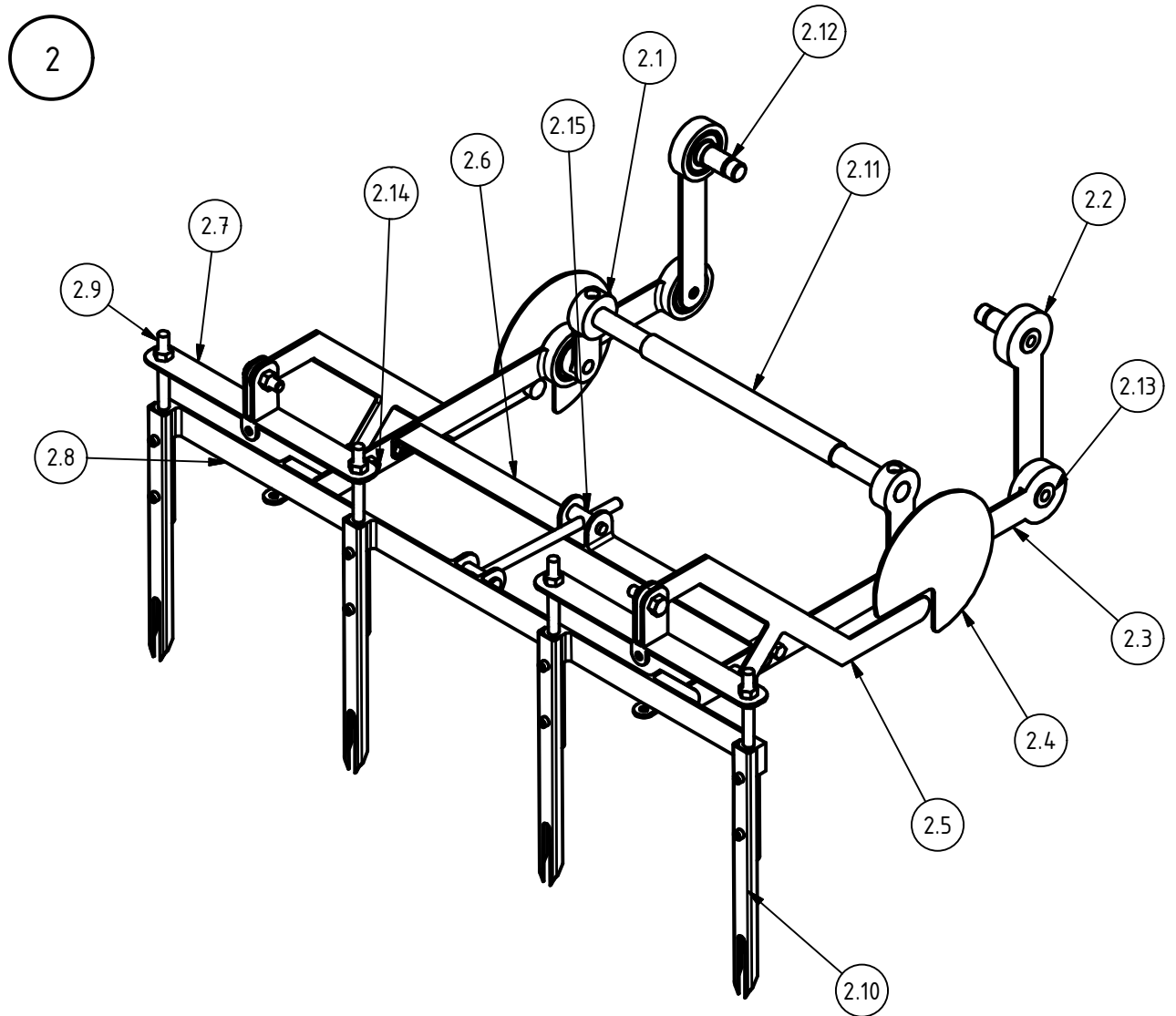

## PARTS LIST

ITEM	QTY	PART NUMBER	DESCRIPTION
2.1	2	Lengan Penggerak	
2.2	2	Lengan Atas	
2.3	2	Lengan Bawah	
2.4	2	Cam	
2.5	2	Lengan Pengiring	
2.6	1	Penghubung Lengan	
2.7	2	Pemegang Penancap	
2.8	1	Pemegang Penanam	
2.9	4	Penancap	
2.10	4	Garpu Penanam	
2.11	1	Poros Penggerak	
2.12	2	Pin Lengan Atas	
2.13	4	Pin Bantalan	
2.14	2	Pin Lengan Pengiring	
2.15	2	Pin Penghubung	

## Mesin Tanam Padi Elektrik

Skala :	Digambar		Tim
1 : 5	Diperiksa		
	Waktu		
	Dilihat		

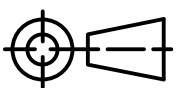

TEKNIK MESIN FT UNY

Kelompok 9

A4

2.1

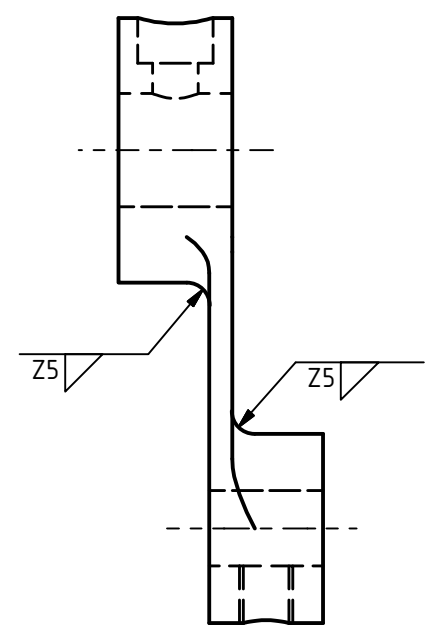
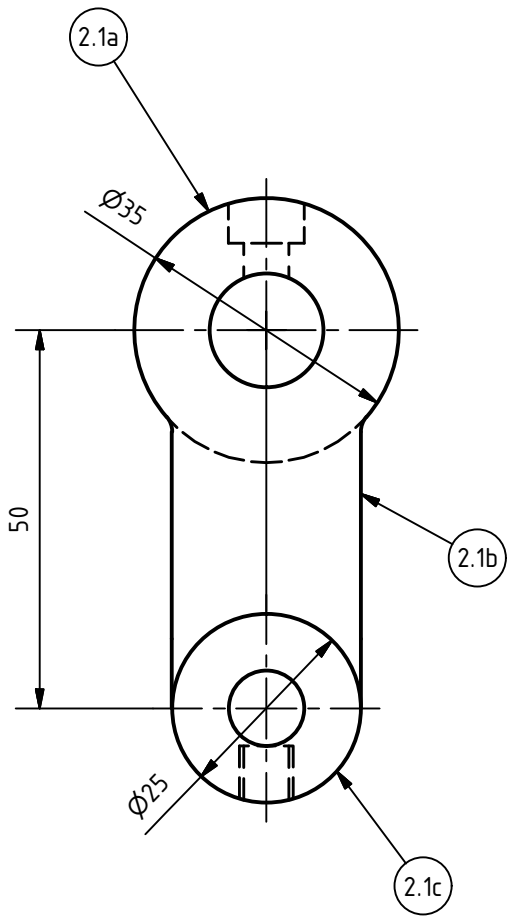
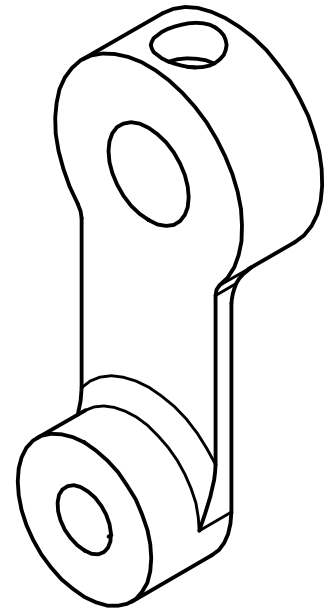

PARTS LIST

ITEM	QTY	PART NUMBER	DESCRIPTION
2.1	2	Lengan Penggerak	

Mesin Tanam Padi Elektrik

Skala :	Digambar		T i m
1 : 1	Diperiksa		
	Waktu		
	Dilihat		

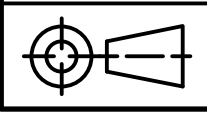

TEKNIK MESIN FT UNY

Kelompok 9 A4

2.1a

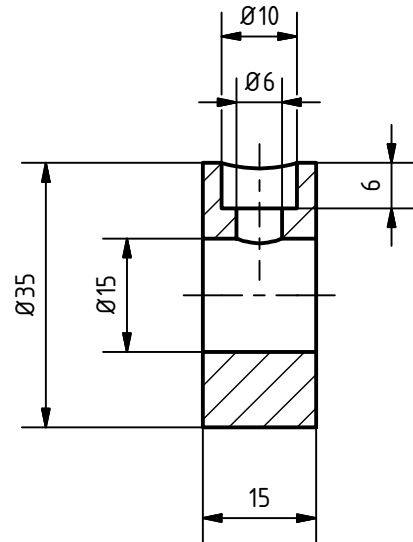

2.1b

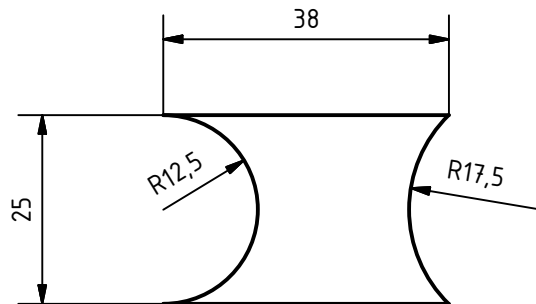

2.1c

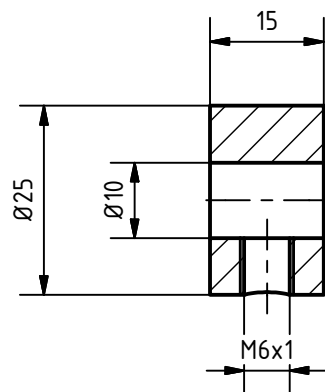

## PARTS LIST

ITEM	QTY	PART NUMBER	DESCRIPTION			
2.1	2	Lengan Penggerak				
Mesin Tanam Padi Elektrik			Skala :	Digambar		Tim
			1 : 1	Diperiksa		
				Waktu		
				Dilihat		
		TEKNIK MESIN FT UNY		Kelompok 9		A4

2.2

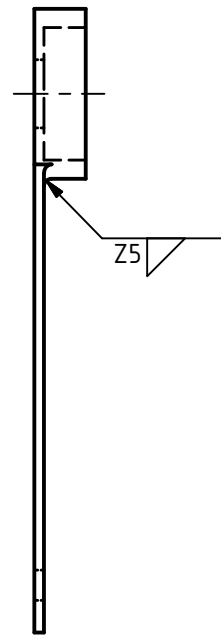
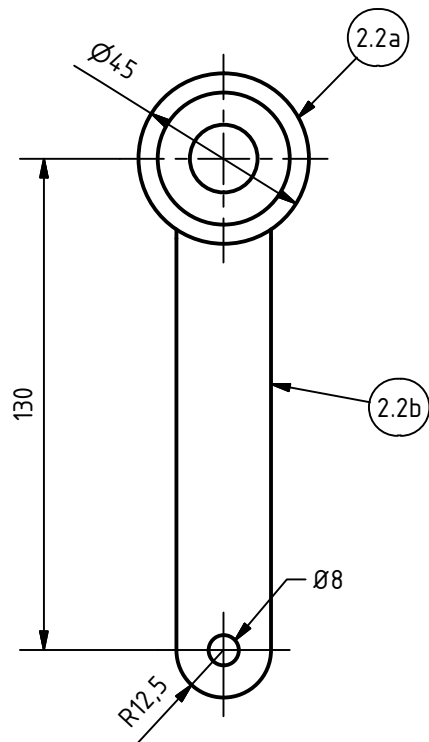
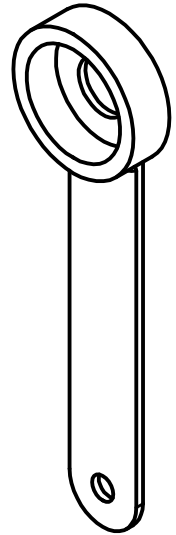

PARTS LIST						
ITEM	QTY	PART NUMBER	DESCRIPTION			
2.2	2	Lengan Atas				
Mesin Tanam Padi Elektrik			Skala :	Digambar		Tim
			1 : 2	Diperiksa		
				Waktu		
				Dilihat		
	TEKNIK MESIN FT UNY		Kelompok 9		A4	

2.2a

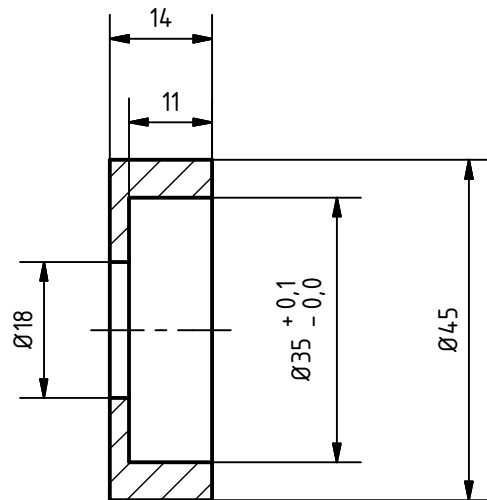

2.2b

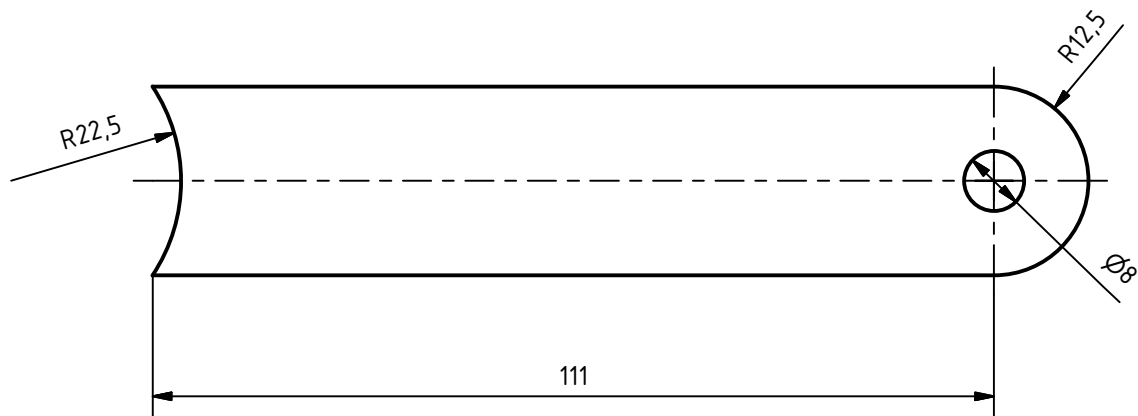

## PARTS LIST

ITEM	QTY	PART NUMBER	DESCRIPTION		
2.2	2	Lengan Atas			
Mesin Tanam Padi Elektrik			Skala :	Digambar	Tim
			1 : 1	Diperiksa	
				Waktu	
				Dilihat	
		TEKNIK MESIN FT UNY	Kelompok 9		A4



2.3

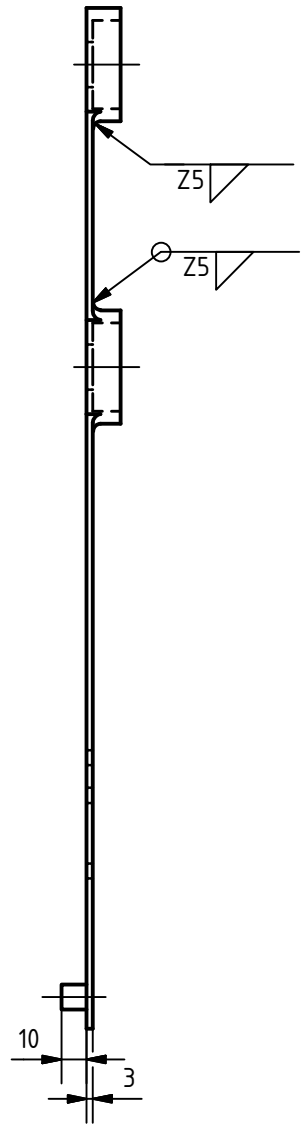
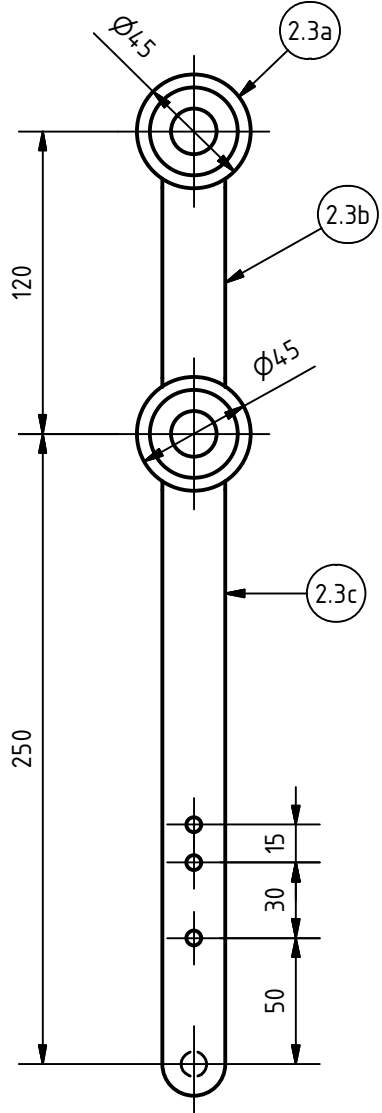
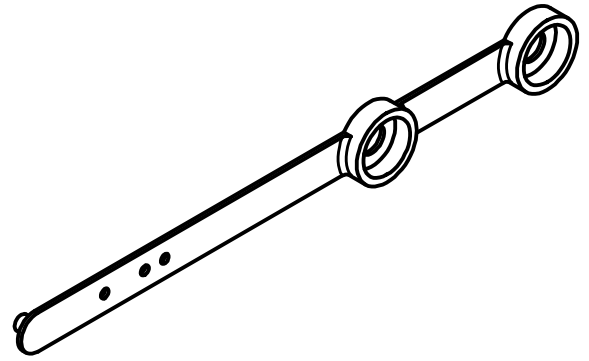

PARTS LIST

ITEM	QTY	PART NUMBER	DESCRIPTION
2.3	2	Lengan Bawah	

<h2>Mesin Tanam Padi Elektrik</h2>	Skala :	Digambar		Tim
	1 : 3	Diperiksa		
		Waktu		
		Dilihat		

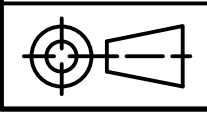

TEKNIK MESIN FT UNY

Kelompok 9

A4

2.3a

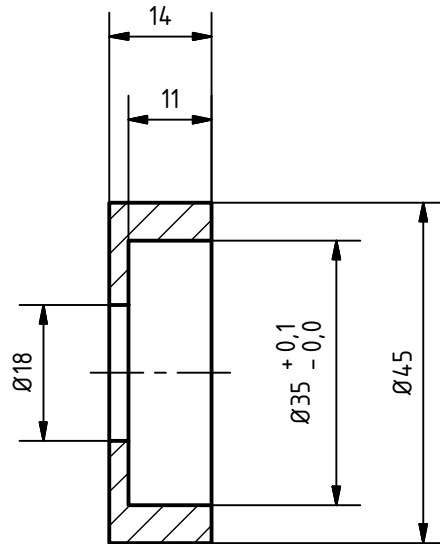

2.3b

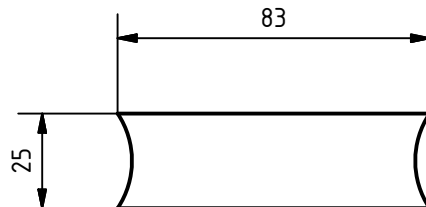

2.3c

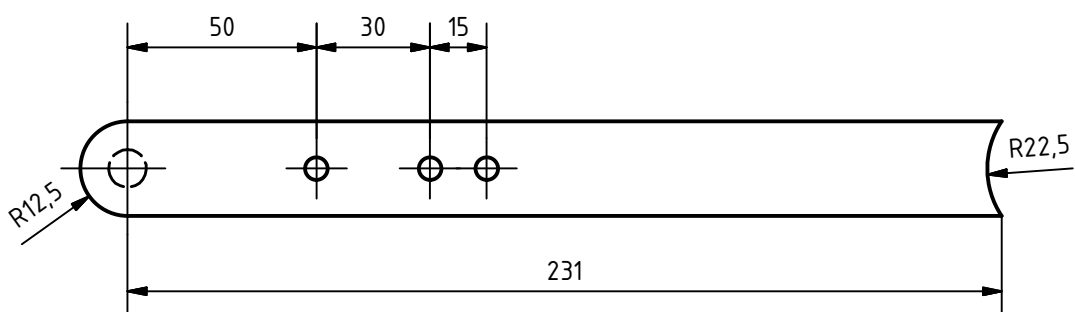

PARTS LIST						
ITEM	QTY	PART NUMBER	DESCRIPTION			
2.3	2	Lengan Bawah				
Mesin Tanam Padi Elektrik			Skala :	Digambar		Tim
			1 : 1	Diperiksa		
				Waktu		
				Dilihat		
	TEKNIK MESIN FT UNY		Kelompok 9		A4	

2.4

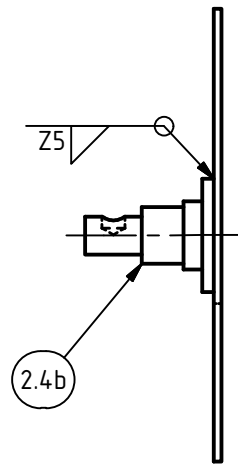
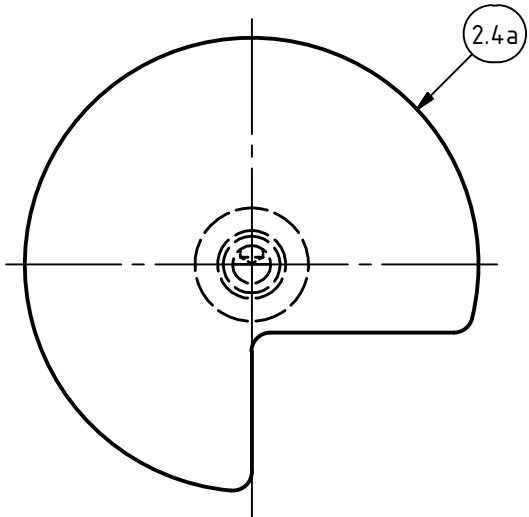
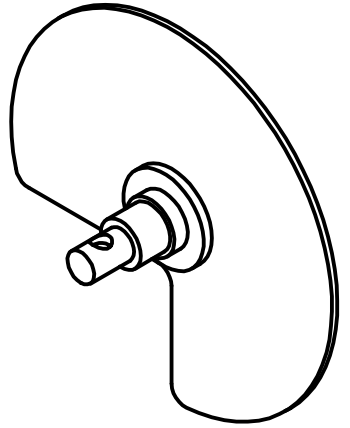

PARTS LIST

ITEM	QTY	PART NUMBER	DESCRIPTION
2.4	2	Cam	

Mesin Tanam Padi Elektrik	Skala :	Digambar		Tim
	1 : 2	Diperiksa		
		Waktu		
		Dilihat		

	TEKNIK MESIN FT UNY	Kelompok 9	A4
--	---------------------	------------	----

2.4a

Skala 1:2

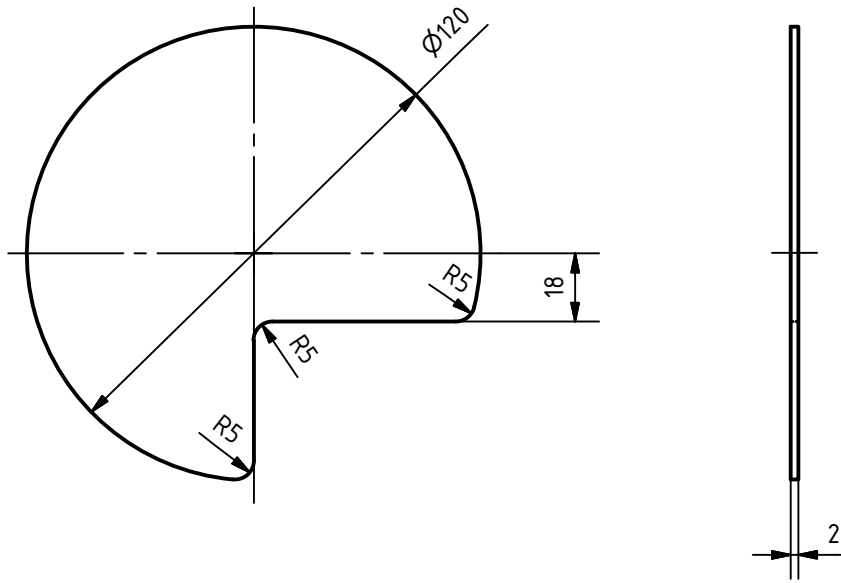

2.4b

Skala 2:1

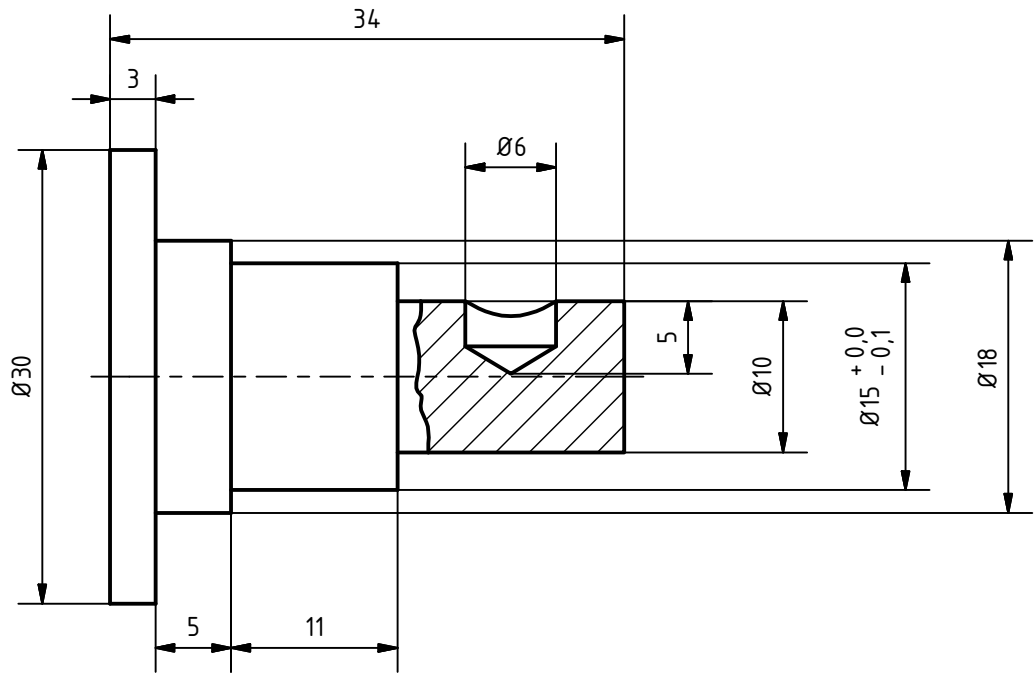

PARTS LIST

ITEM	QTY	PART NUMBER	DESCRIPTION
2.4	2	Cam	

Mesin Tanam Padi Elektrik

Skala :	Digambar		Tim
On Part	Diperiksa		
	Waktu		
	Dilihat		

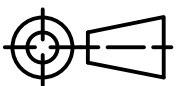

TEKNIK MESIN FT UNY

16508134019

A4

2.5

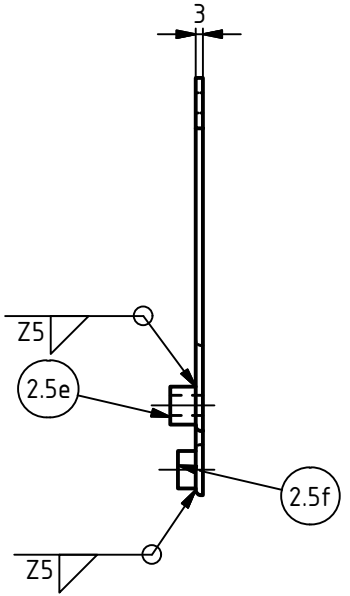
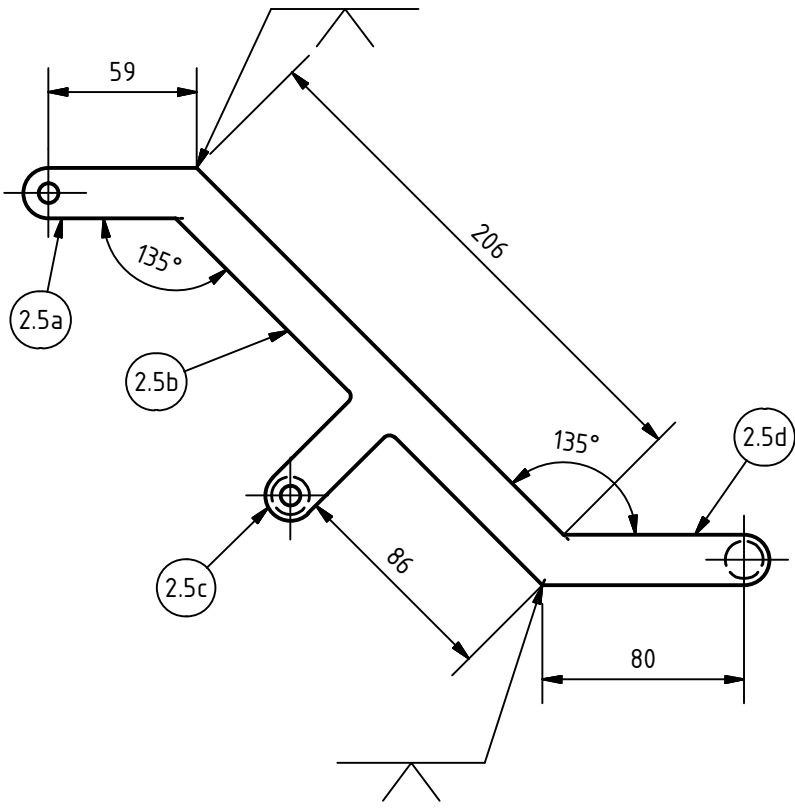
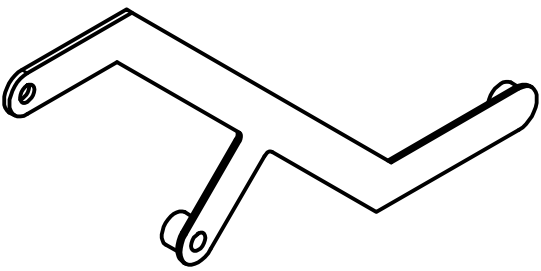

PARTS LIST

ITEM	QTY	PART NUMBER	DESCRIPTION
2.5	2	Lengan Pengiring	

<h2>Mesin Tanam Padi Elektrik</h2>	Skala :	Digambar		Tim
	1 : 3	Diperiksa		
		Waktu		
		Dilihat		

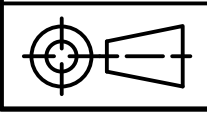

TEKNIK MESIN FT UNY

Kelompok 9

A4

2.5a

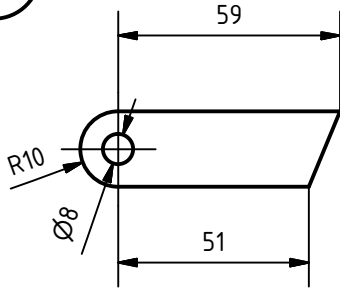

2.5b

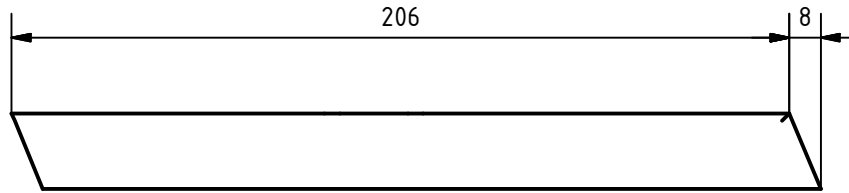

2.5c

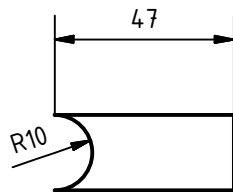

2.5d

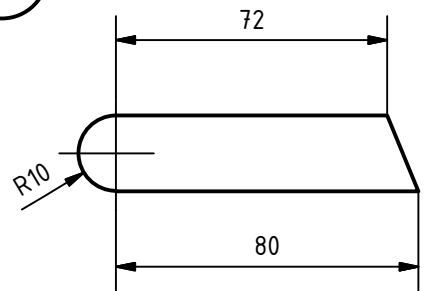

2.5e

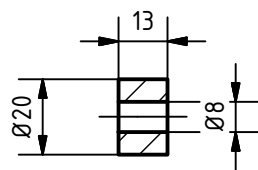

2.5f

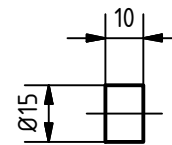

PARTS LIST

ITEM	QTY	PART NUMBER	DESCRIPTION
2.5	2	Lengan Pengiring	

Mesin Tanam Padi Elektrik

Skala :	Digambar		Tim
1 : 2	Diperiksa		
	Waktu		
	Dilihat		

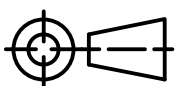

TEKNIK MESIN FT UNY

Kelompok 9

A4

2.6

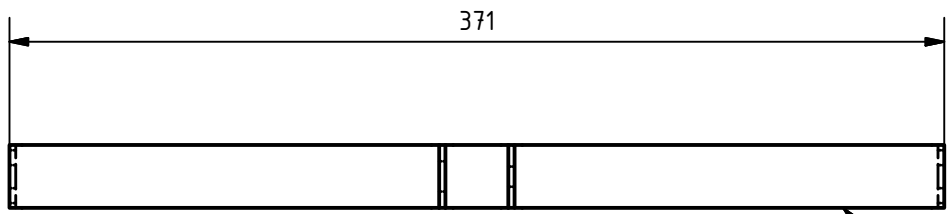
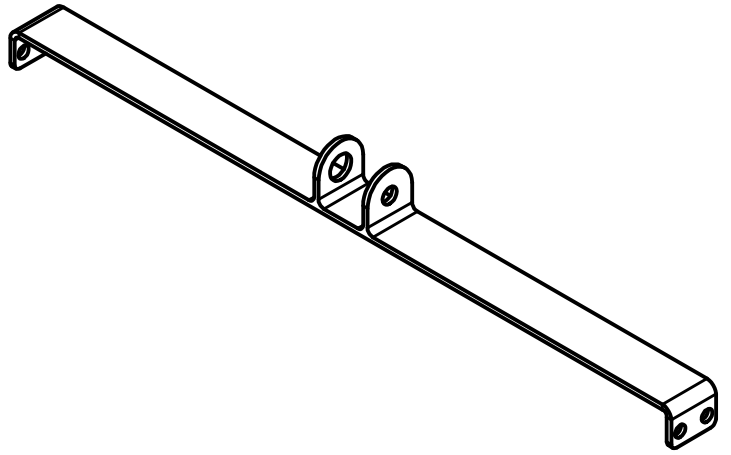

2.6a

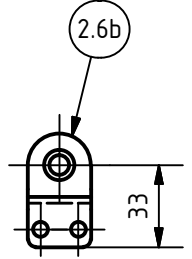
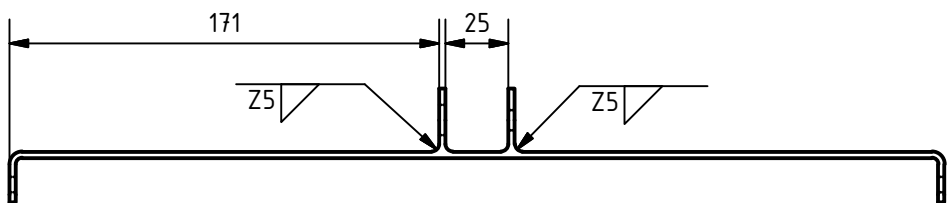

PARTS LIST

ITEM	QTY	PART NUMBER	DESCRIPTION
2.6	1	Penghubung Lengan	

Mesin Tanam Padi Elektrik	Skala :	Digambar		T i m
	1 : 3	Diperiksa		
		Waktu		
		Dilihat		

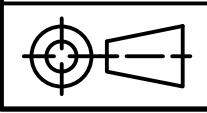

TEKNIK MESIN FT UNY

Kelompok 9      A4

2.6a

Skala 1:2

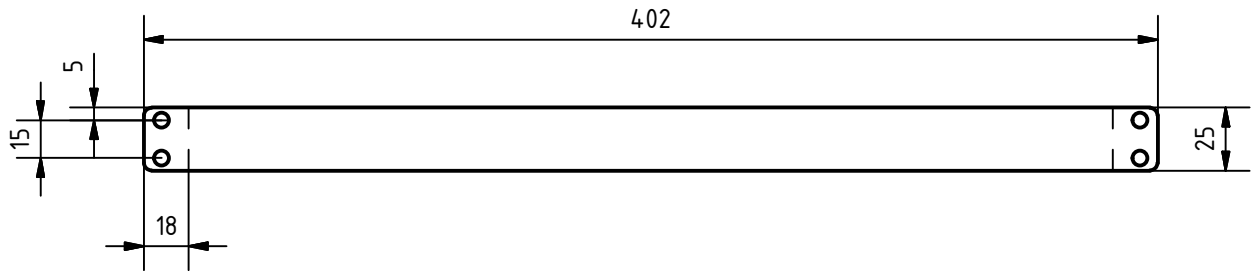

2.6b

Skala 1:1

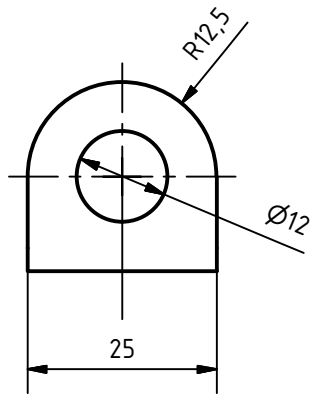

PARTS LIST

ITEM	QTY	PART NUMBER	DESCRIPTION
2.6	1		Penghubung Lengan

Mesin Tanam Padi Elektrik

Skala :	Digambar		Tim
On Part	Diperiksa		
	Waktu		
	Dilihat		

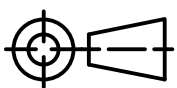

TEKNIK MESIN FT UNY

Kelompok 9

A4



2.7

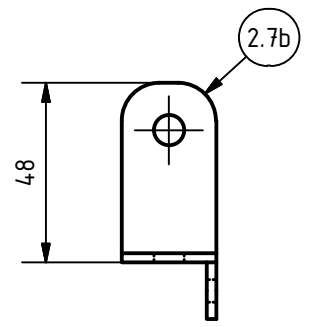
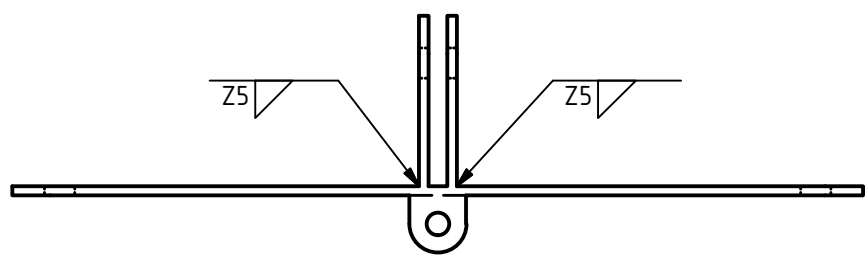
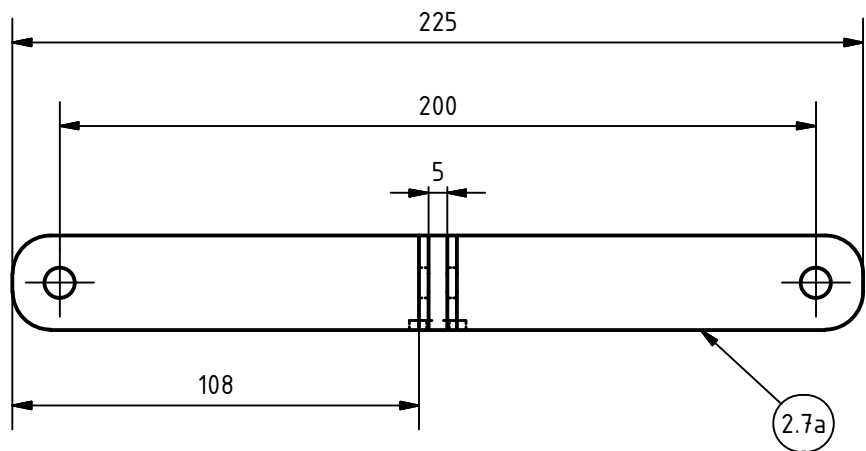
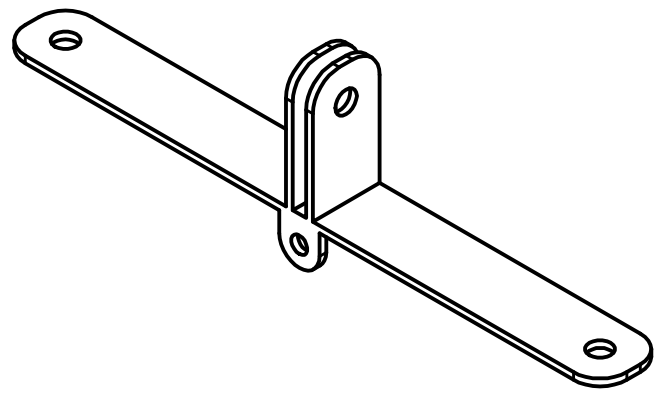

PARTS LIST

ITEM	QTY	PART NUMBER	DESCRIPTION
2.7	2		Pemegang Penancap

Mesin Tanam Padi Elektrik	Skala :	Digambar		Tim
	1 : 2	Diperiksa		
		Waktu		
		Dilihat		

2.7a

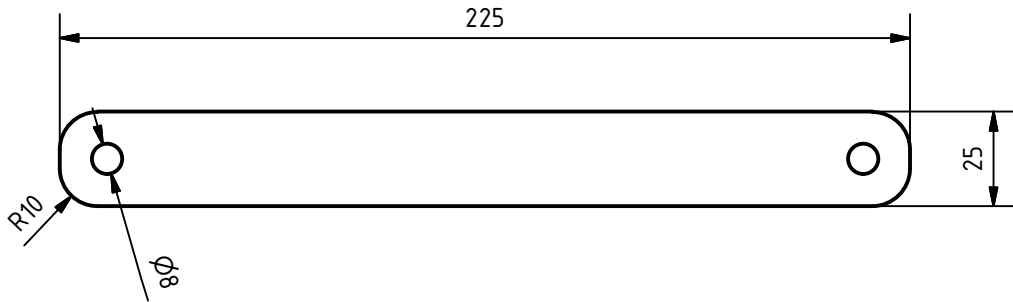

2.7b

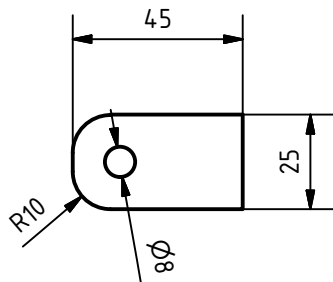

PARTS LIST			
ITEM	QTY	PART NUMBER	DESCRIPTION
2.7	2	Pemegang Penancap	
Mesin Tanam Padi Elektrik			Skala :
			1 : 2
TEKNIK MESIN FT UNY		Kelompok 9	
		A4	

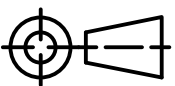

2.8

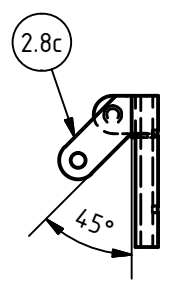
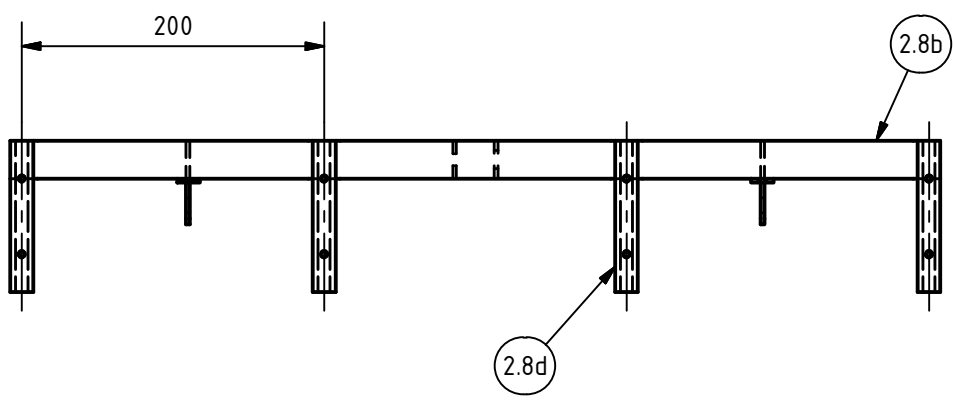
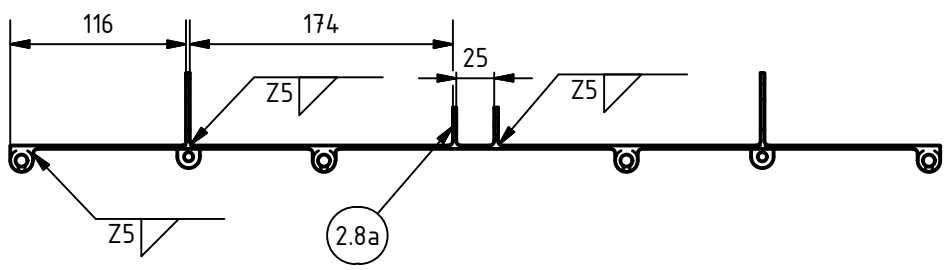
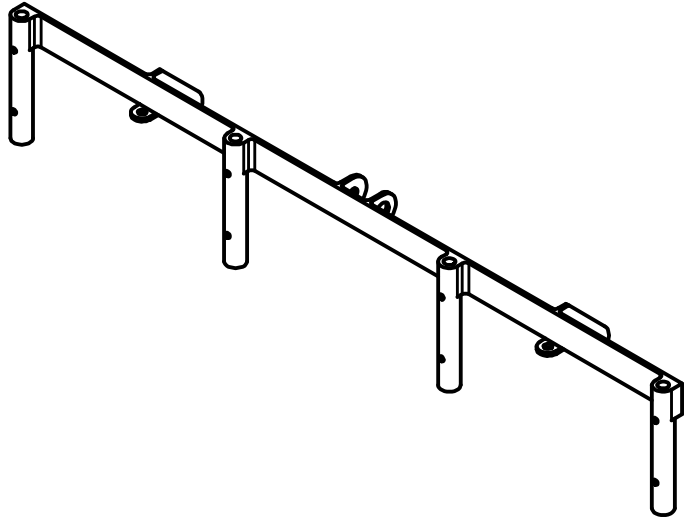

PARTS LIST

ITEM	QTY	PART NUMBER	DESCRIPTION
2.8	1	Pemegang Penanam	

Mesin Tanam Padi Elektrik

Skala :	Digambar		T i m
1 : 2	Diperiksa		
	Waktu		
	Dilihat		

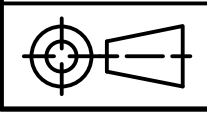

TEKNIK MESIN FT UNY

Kelompok 9 A4

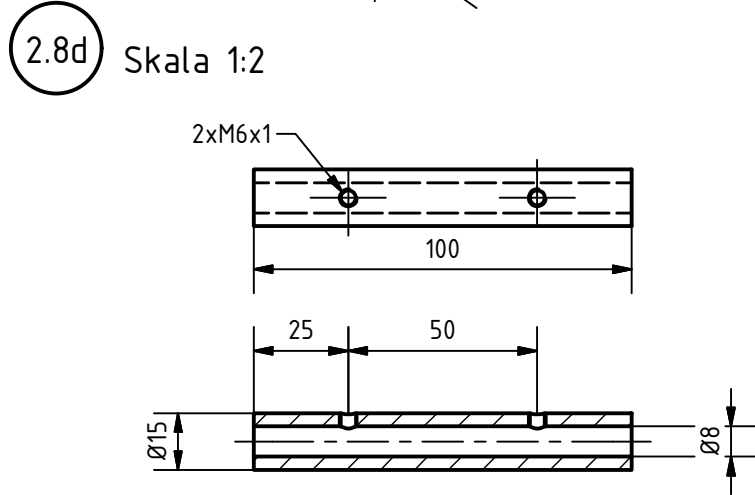
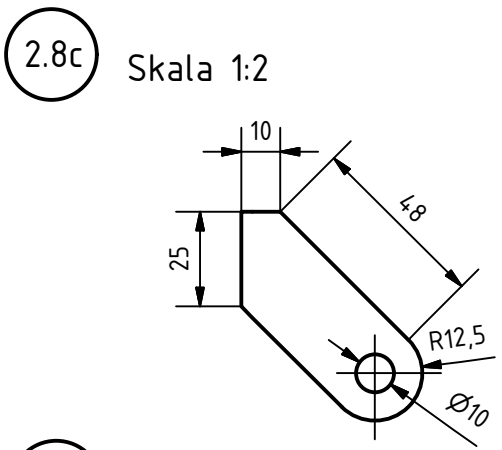
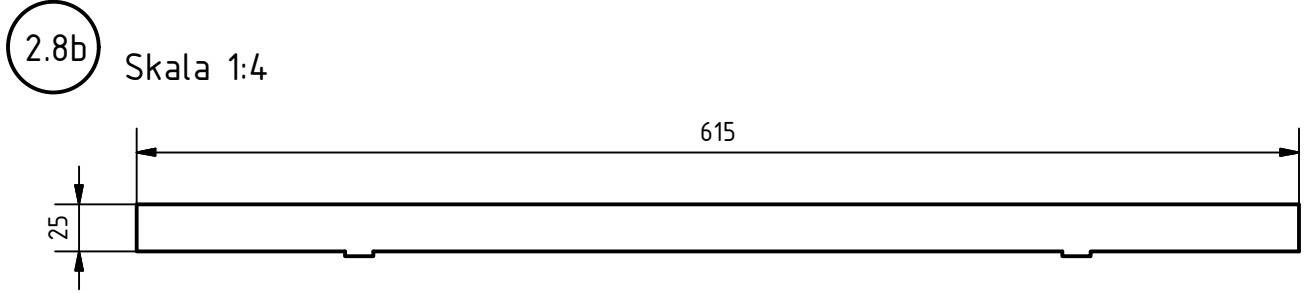
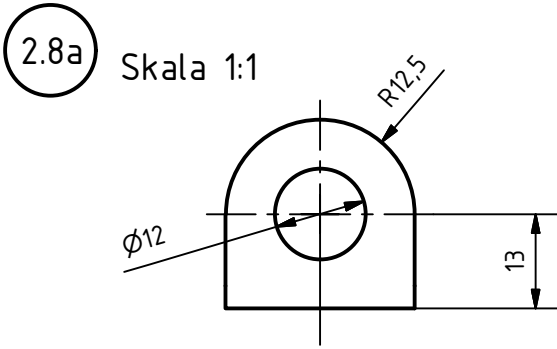

PARTS LIST						
ITEM	QTY	PART NUMBER	DESCRIPTION			
2.8	1	Pemegang Penanam				
<h2>Mesin Tanam Padi Elektrik</h2>			Skala :	Digambar		Tim
			On Part	Diperiksa		
				Waktu		
				Dilihat		
	TEKNIK MESIN FT UNY		Kelompok 9	A4		

2.9

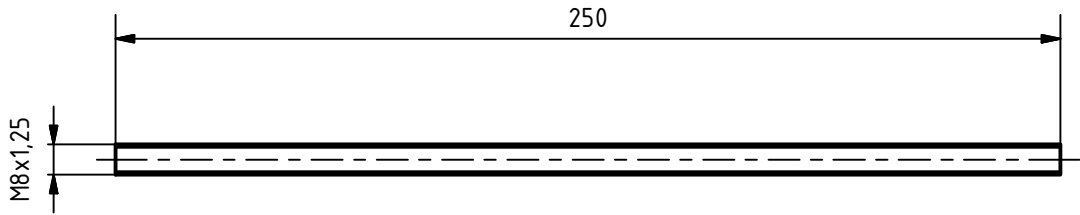

2.10

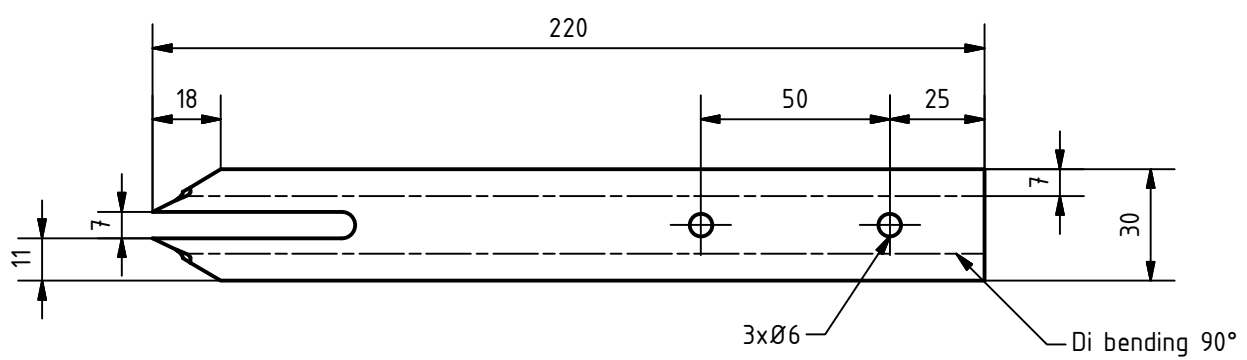

PARTS LIST

ITEM	QTY	PART NUMBER	DESCRIPTION
2.9	4	Penancap	
2.10	4	Garpu Penanam	

Mesin Tanam Padi Elektrik

Skala :	Digambar		Tim
1 : 2	Diperiksa		
	Waktu		
	Dilihat		

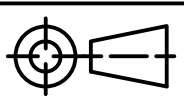

TEKNIK MESIN FT UNY

Kelompok 9

A4

2.11

Skala 1:2

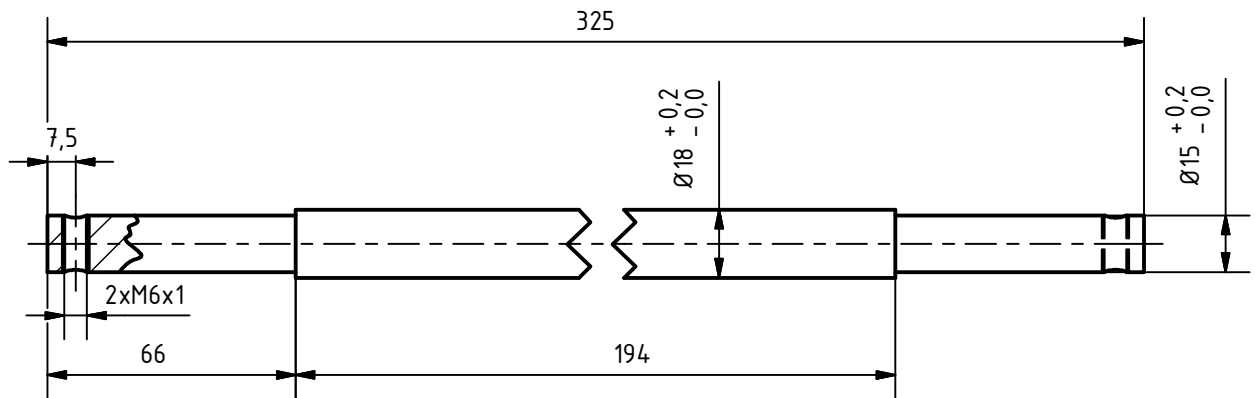

2.12

Skala 2:1

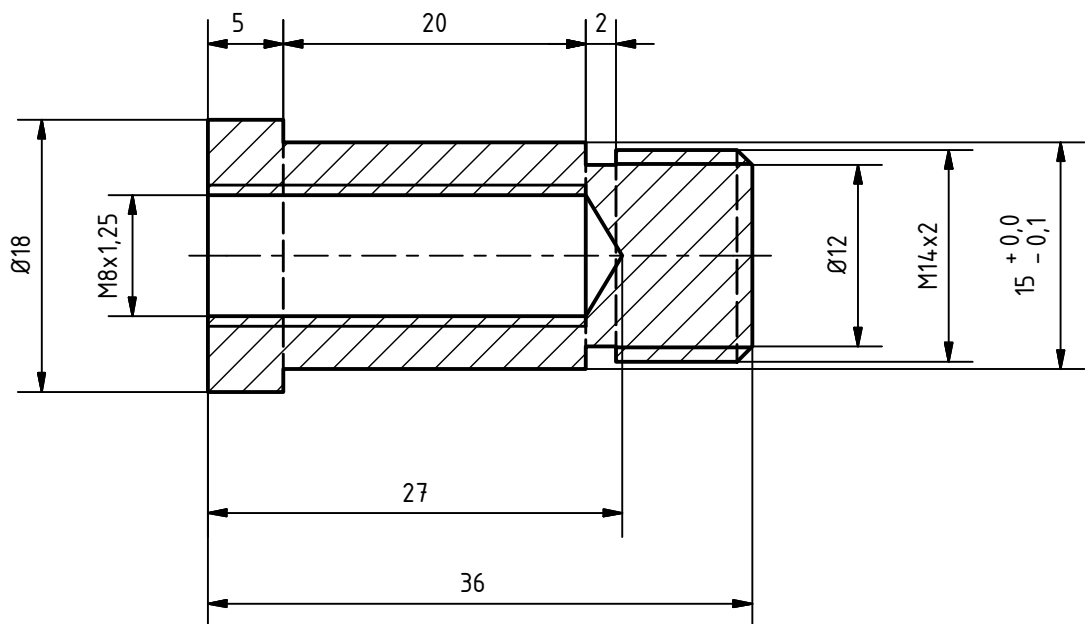

## PARTS LIST

ITEM	QTY	PART NUMBER	DESCRIPTION
2.11	1	Poros Penggerak	
2.12	2	Pin Lengan Atas	

Mesin Tanam Padi Elektrik

Skala :	Digambar		Tim
On Part	Diperiksa		
	Waktu		
	Dilihat		

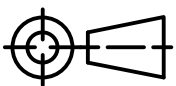

TEKNIK MESIN FT UNY

Kelompok 9

A4

2.13

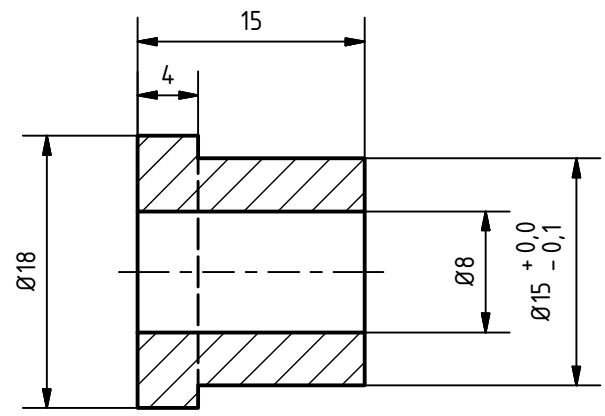

2.14

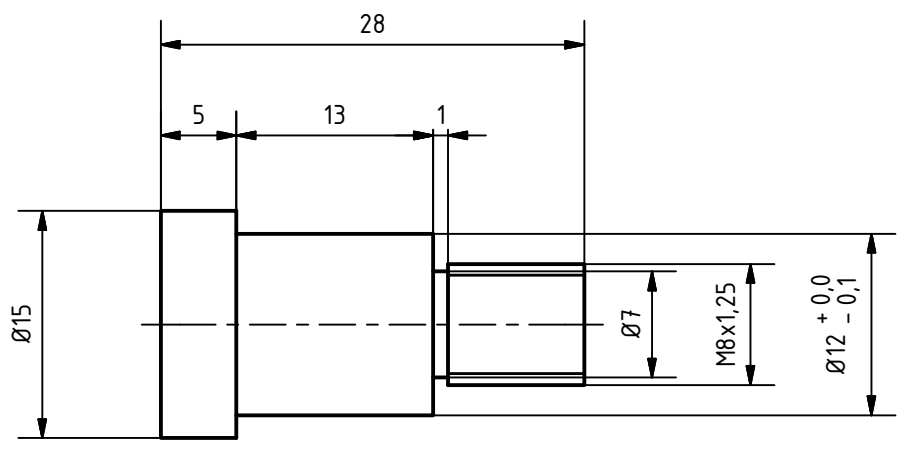

2.15

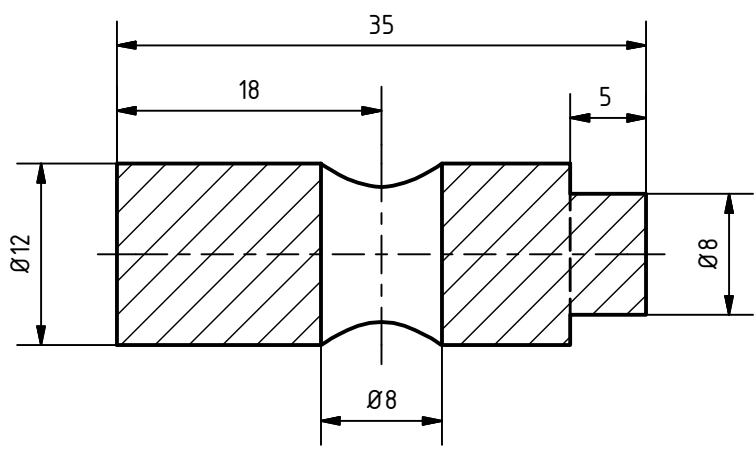

PARTS LIST

ITEM	QTY	PART NUMBER	DESCRIPTION
2.13	4	Pin Bantalan	
2.14	2	Pin Lengan Pengiring	
2.15	2	Pin Penghubung	

Mesin Tanam Padi Elektrik

Skala :	Digambar		Tim
	2 : 1	Diperiksa	
		Waktu	
		Dilihat	

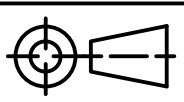

TEKNIK MESIN FT UNY

Kelompok 9

A4

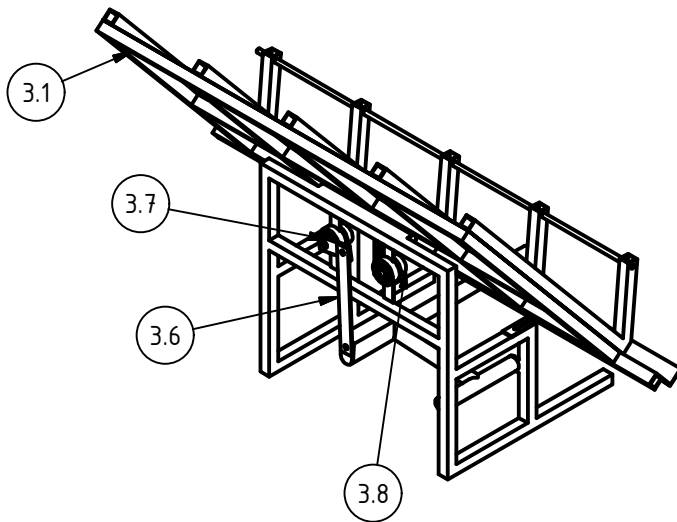
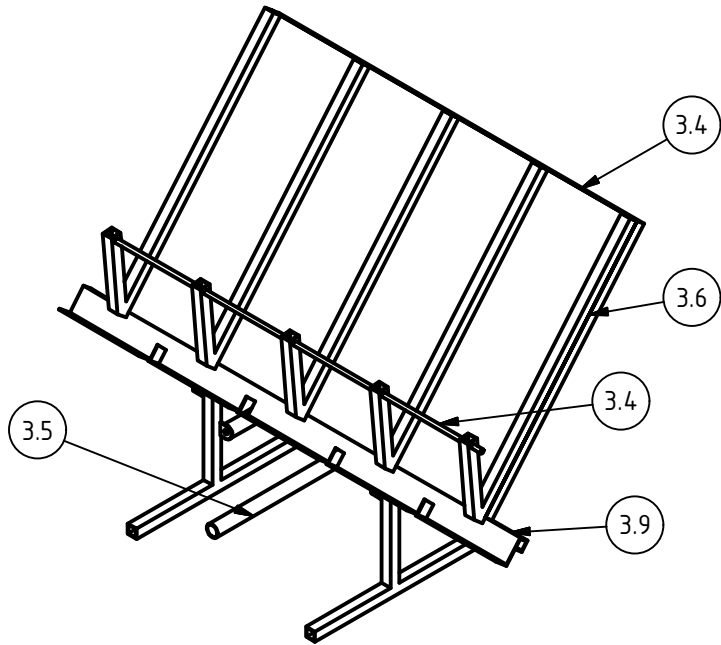

PARTS LIST

ITEM	QTY	PART NUMBER	DESCRIPTION
3.1	1	Rangka Meja Penampung	
3.2	1	Alas Meja Penampung	
3.3	5	Penyekat	
3.4	1	Penahan Bibit	
3.5	1	Tuas Meja Penampung	
3.6	1	Tuas Penghubung	
3.7	1	Tuas Roda Gigi	
3.8	2	Poros Roda Gigi	
3.9	1	Lintasan Meja Penampung	

Mesin Tanam Padi Elektrik

Skala :	Digambar		Tim
1 : 12	Diperiksa		
	Waktu		
	Dilihat		

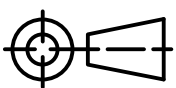

TEKNIK MESIN FT UNY

Kelompok 9

A4



3.1

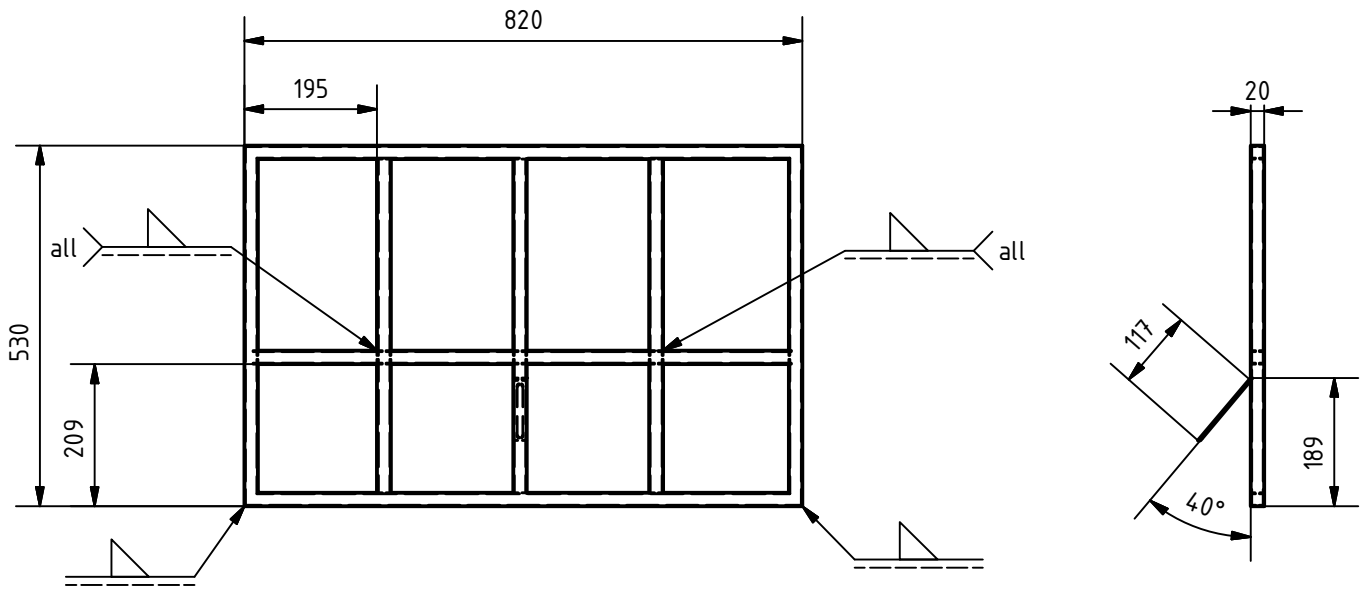
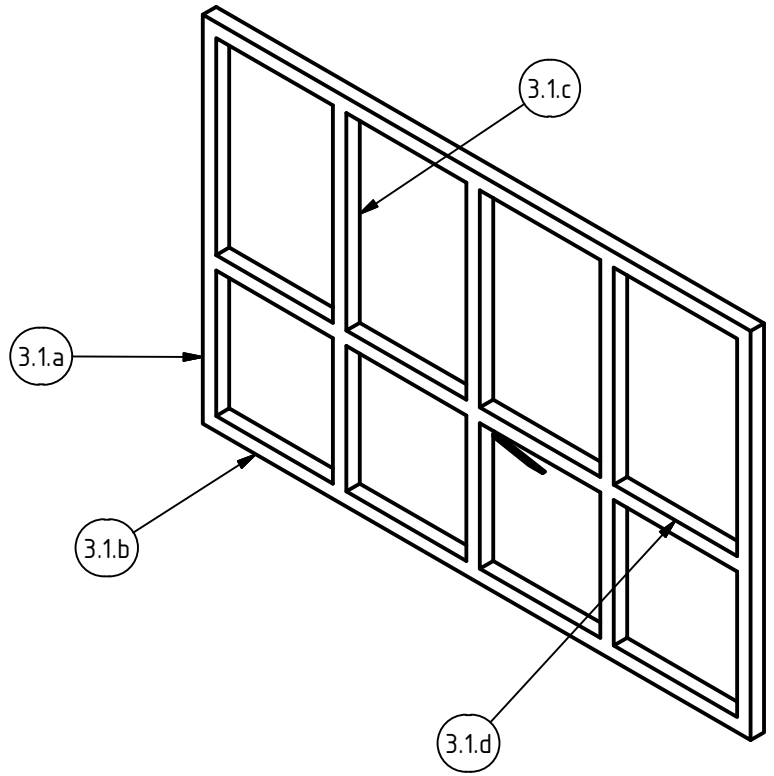

PARTS LIST

ITEM	QTY	PART NUMBER	DESCRIPTION
3.1	1		rangka meja penampung benih

Mesin Tanam Padi Elektrik

Skala :	Digambar	10-10-18	T i m
1 : 8	Diperiksa		
	Waktu		
	Dilihat		

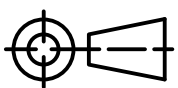

TEKNIK MESIN FT UNY

Kelompok 9

A4

3.1.a part a

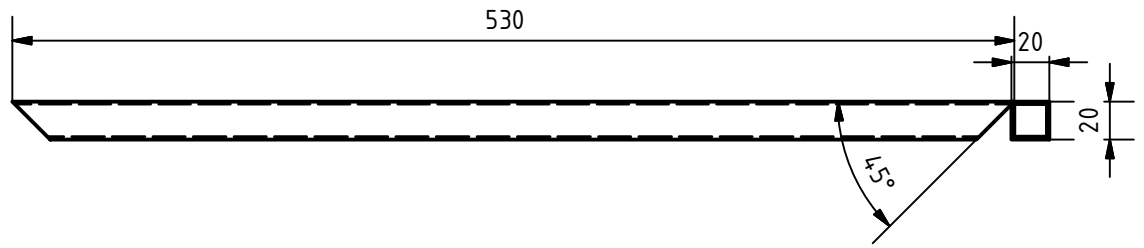

3.1.b part b

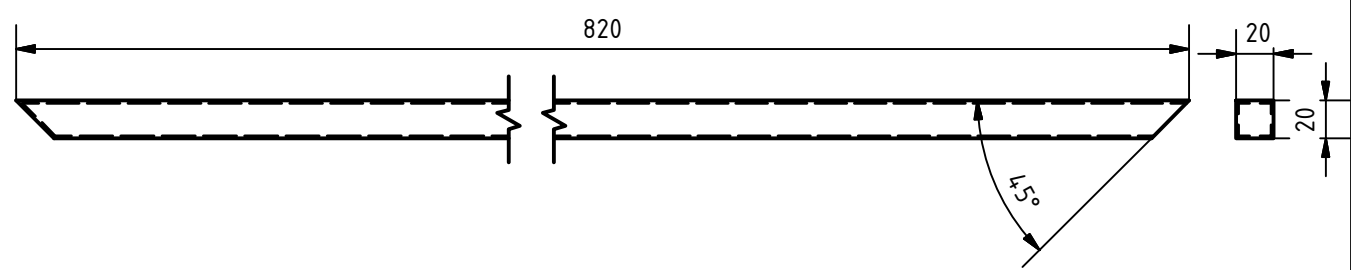

3.1.c part c

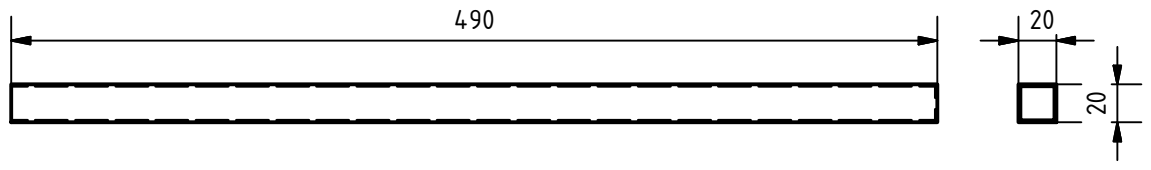

3.1.d part d

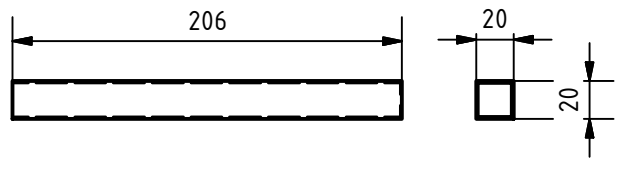

PARTS LIST

ITEM	QTY	PART NUMBER	DESCRIPTION
3.1.a	1		rangka meja penampung bibit

Mesin Tanam Padi Elektrik

Skala :	Digambar	10-10-18	T i m
1:8	Diperiksa		
	Waktu		
	Dilihat		

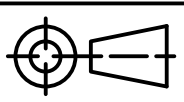

TEKNIK MESIN FT UNY

Kelompok 9

A4

3.2

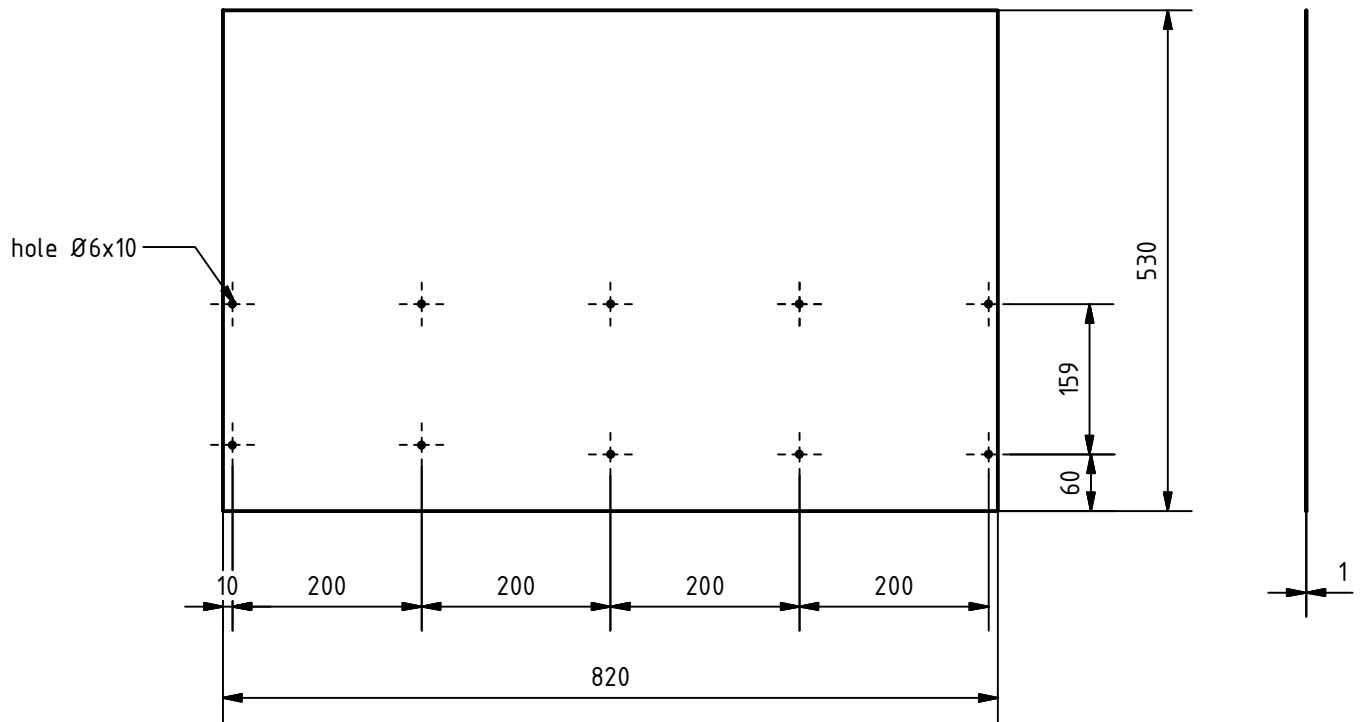
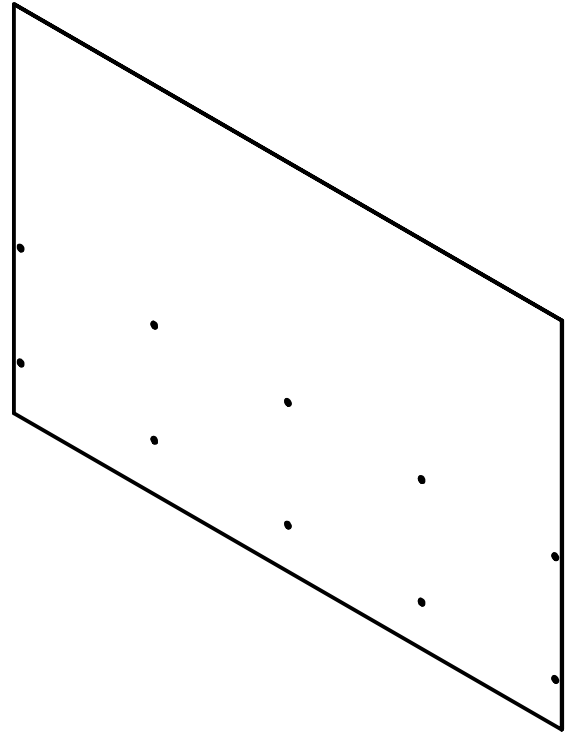

PARTS LIST

ITEM	QTY	PART NUMBER	DESCRIPTION
3.2	1	alas meja penanam	

meja penampung benih

Skala :	Digambar	10-10-18	T i m
1 : 8	Diperiksa		
	Waktu		
	Dilihat		

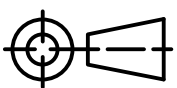

TEKNIK MESIN FT UNY

Kelompok 9

A4

3.3

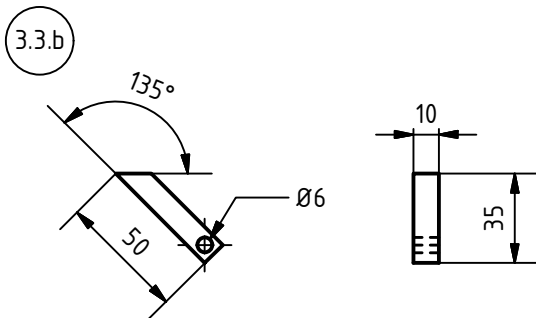
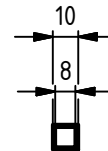
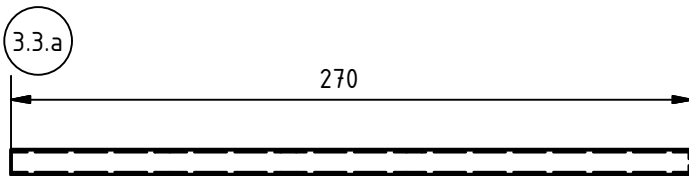
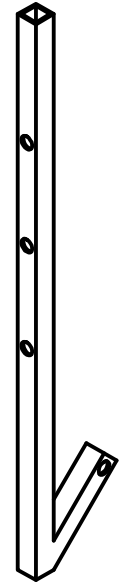
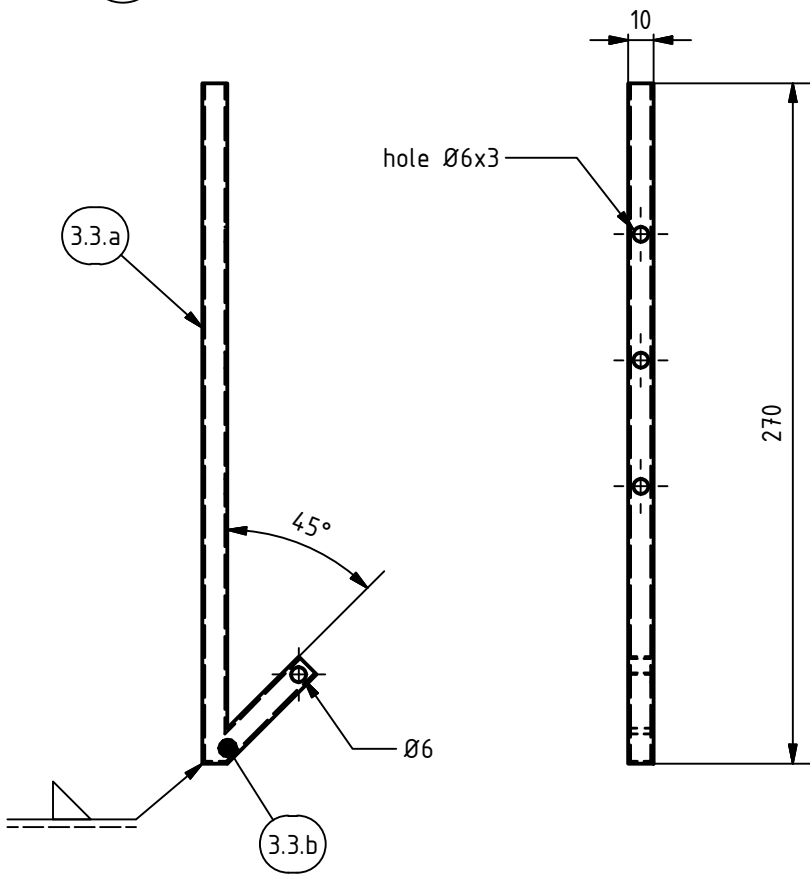

PARTS LIST

ITEM	QTY	PART NUMBER	DESCRIPTION
3.3	5	penyekat	

Mesin Tanam Padi Elektrik

Skala :	Digambar	10-10-18	T i m
1 : 3	Diperiksa		
	Waktu		
	Dilihat		

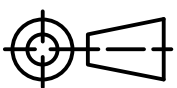

TEKNIK MESIN FT UNY

Kelompok 9

A4

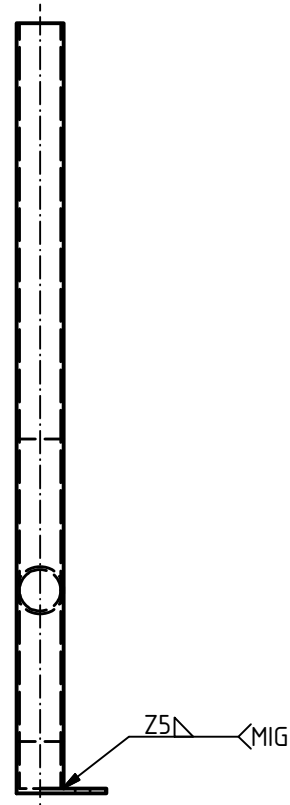
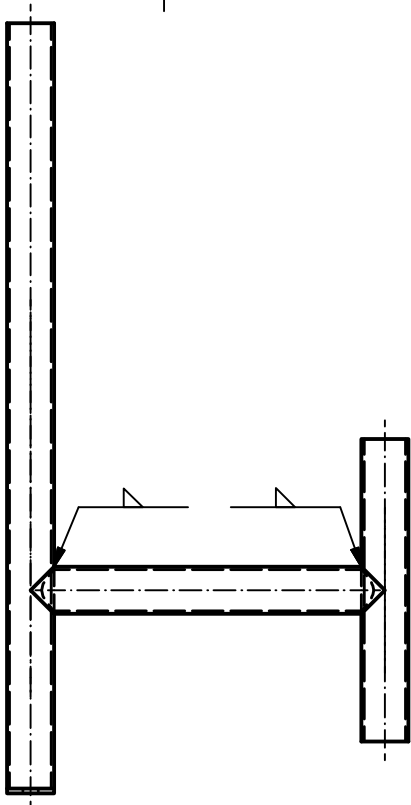
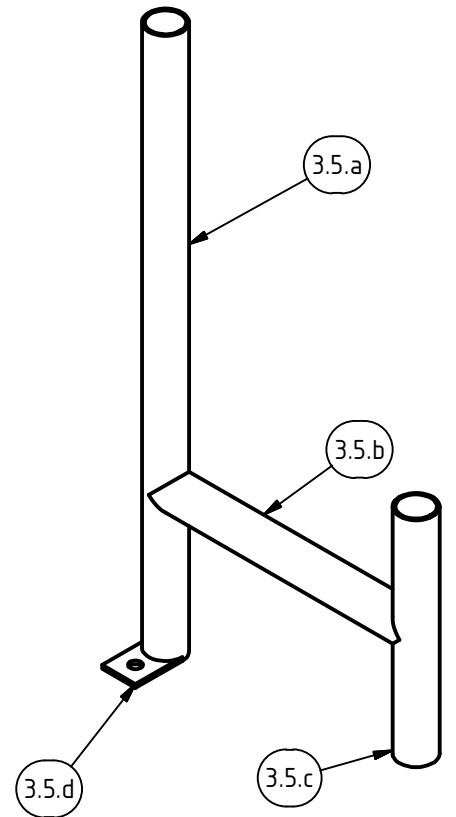
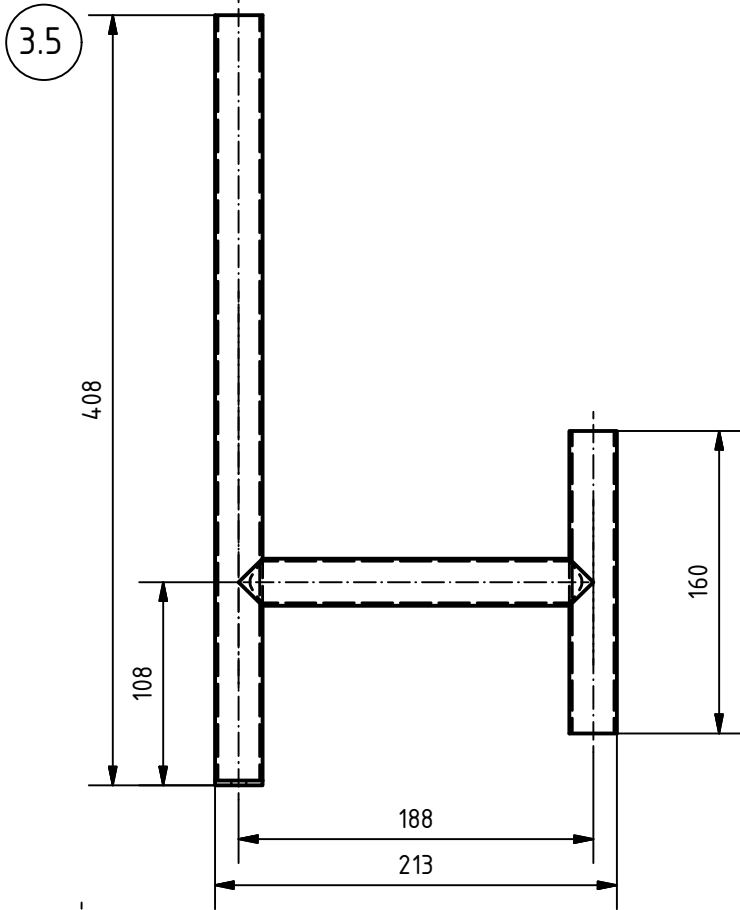

PARTS LIST

ITEM	QTY	PART NUMBER	DESCRIPTION
1	1		tuas meja penampung bibit

Mesin Tanam Padi Elektrik

Skala :	Digambar	10-10-18	T i m
	Diperiksa		
	Waktu		
	Dilihat		

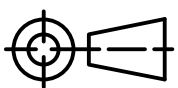

TEKNIK MESIN FT UNY

Kelompok 9

A4

3.5.a

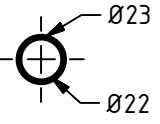
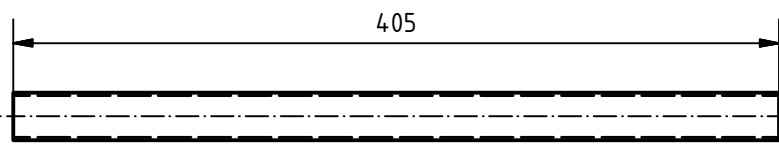

3.5.a

3.5.b

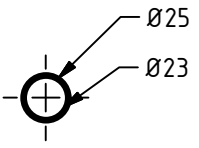
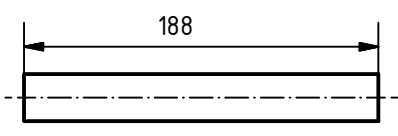

3.5.b

3.5.c

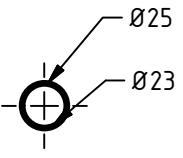
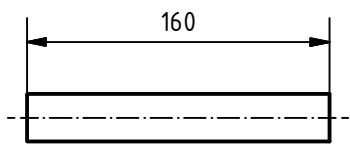

3.5.c

3.5.d

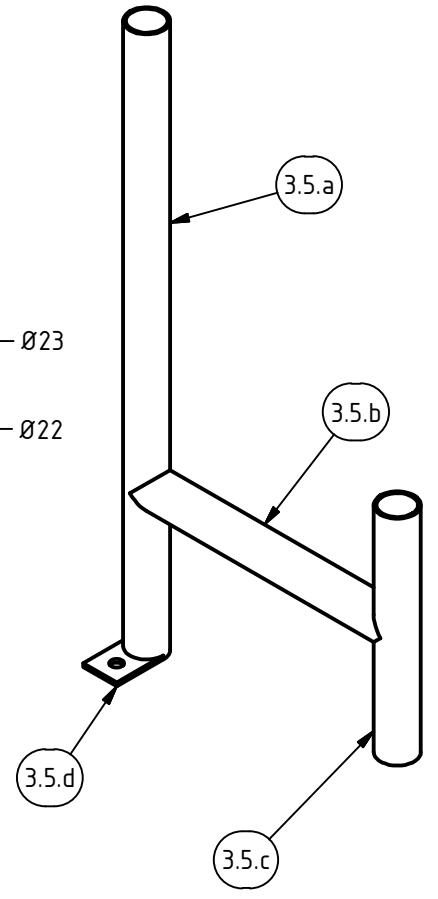
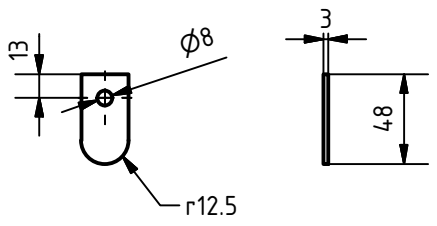

PARTS LIST

ITEM	QTY	PART NUMBER	DESCRIPTION
1	1		tuas meja penampung bibit

Mesin Tanam Padi Elektrik

Skala :	Digambar	10-10-18	T i m
1 : 4	Diperiksa		
	Waktu		
	Dilihat		

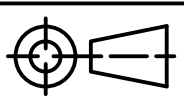

TEKNIK MESIN FT UNY

Kelompok 9

A4

3.4 penahan bibit  
skala 1:5

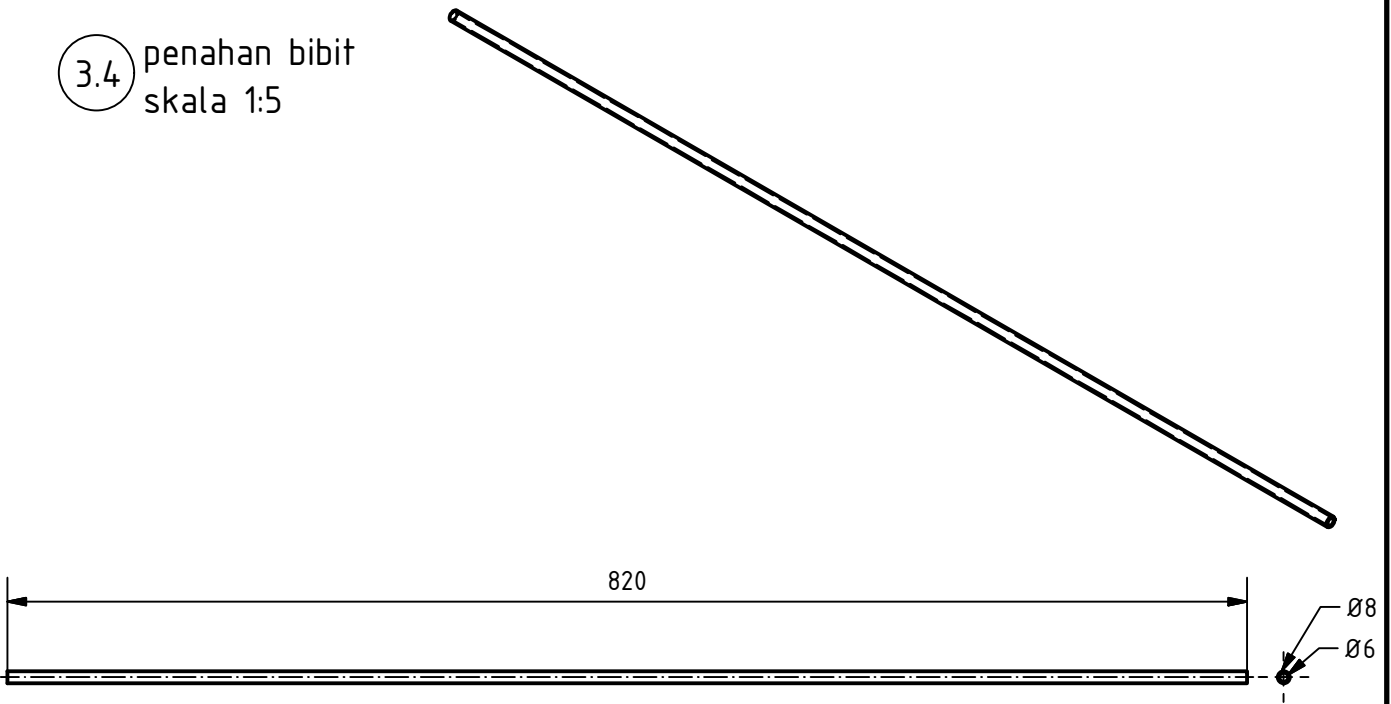

3.6 tuas penghubung  
skala 1:2

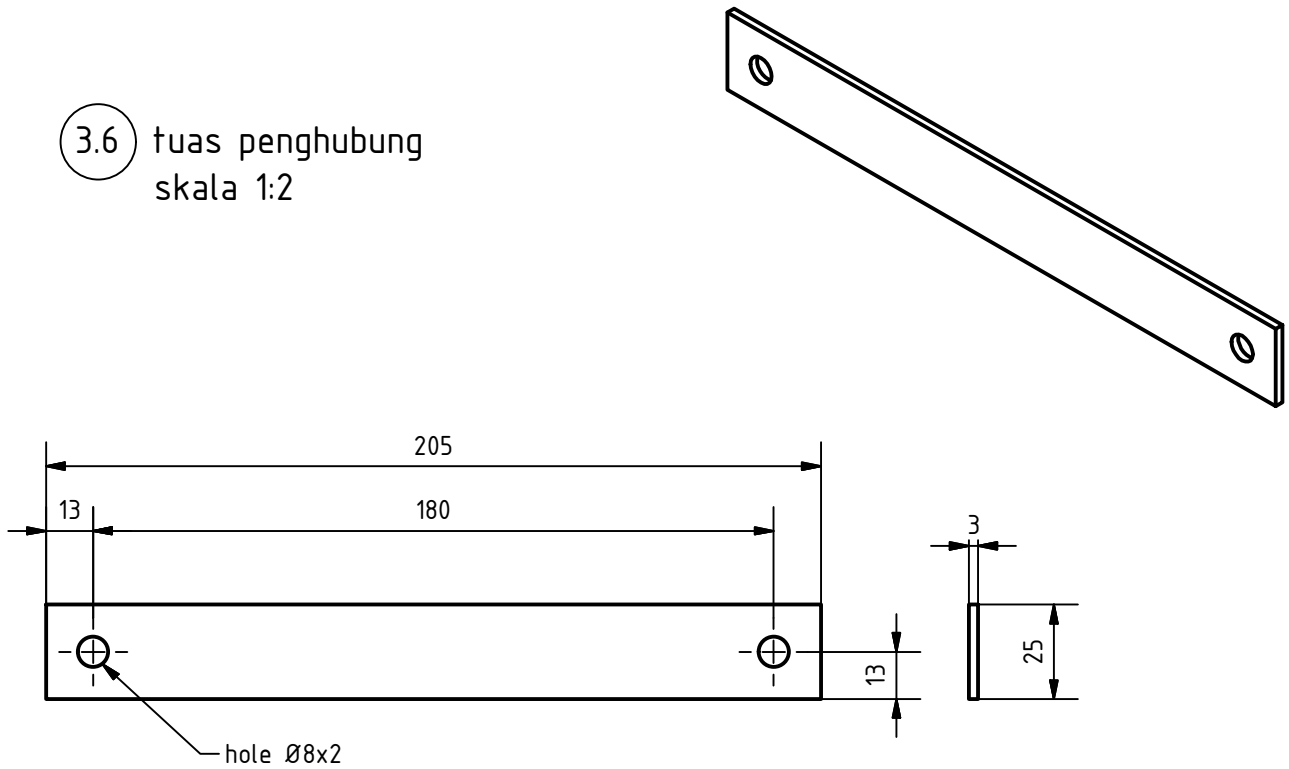

PARTS LIST

ITEM	QTY	PART NUMBER	DESCRIPTION
3.4	1	penahan bibit	
3.6	1	tuas penghubung	

Mesin Tanam Padi Elektrik

Skala :	Digambar	10-10-18	T i m
on part	Diperiksa		
	Waktu		
	Dilihat		

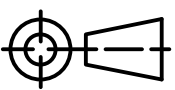

TEKNIK MESIN FT UNY

Kelompok 9

A4

3.7

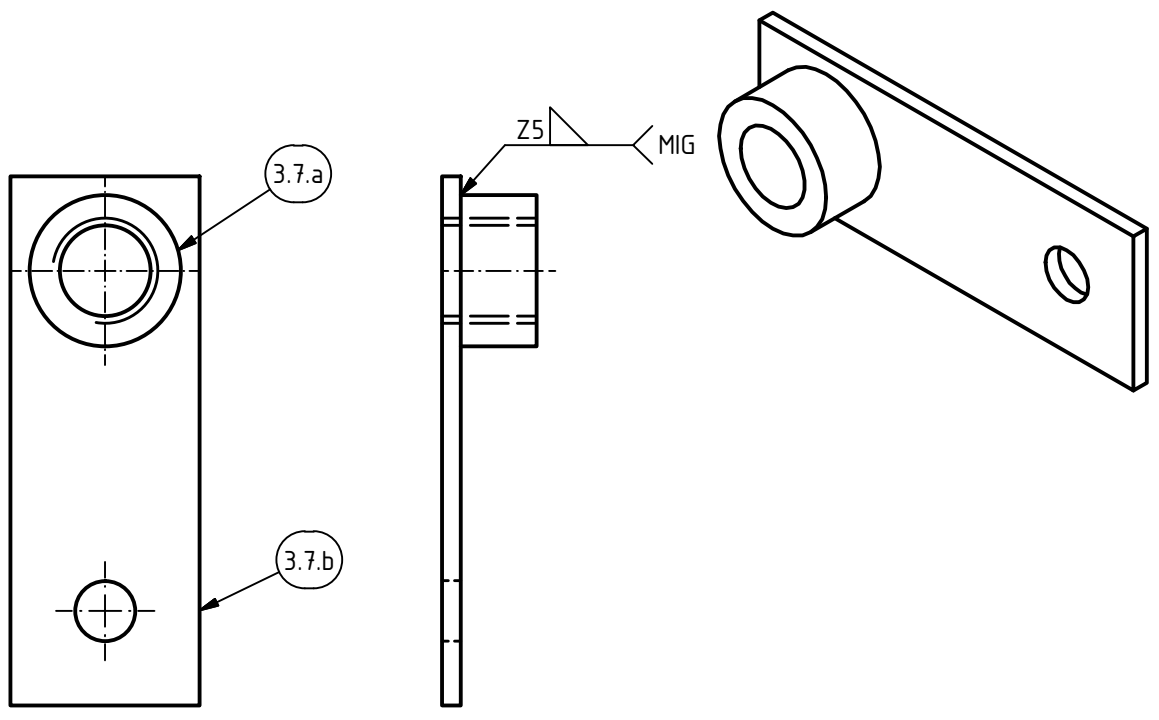

3.7.a

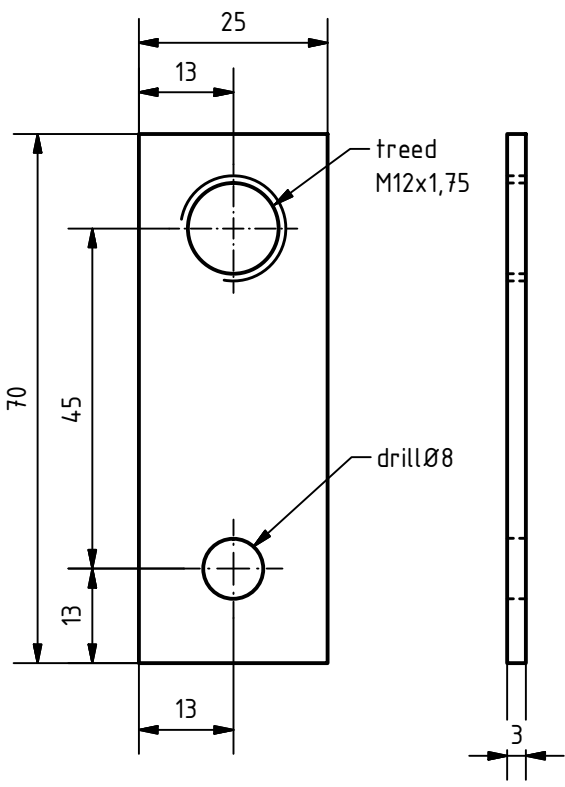

3.7.b

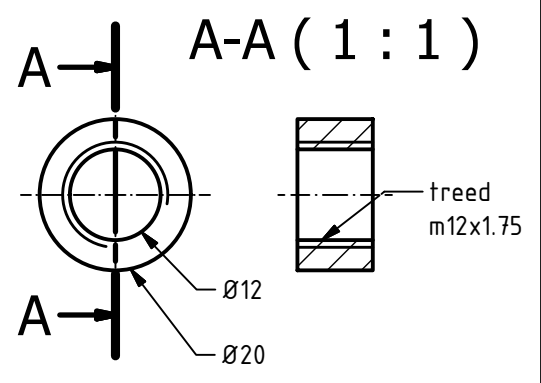

PARTS LIST

ITEM	QTY	PART NUMBER	DESCRIPTION
3.7	1	tuas roda gigi	

Mesin Tanam Padi Elektrik

Skala :	Digambar	10-10-18	T i m
1 : 1	Diperiksa		
	Waktu		
	Dilihat		

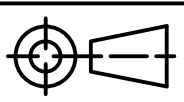

TEKNIK MESIN FT UNY

Kelompok 9

A4



3.7

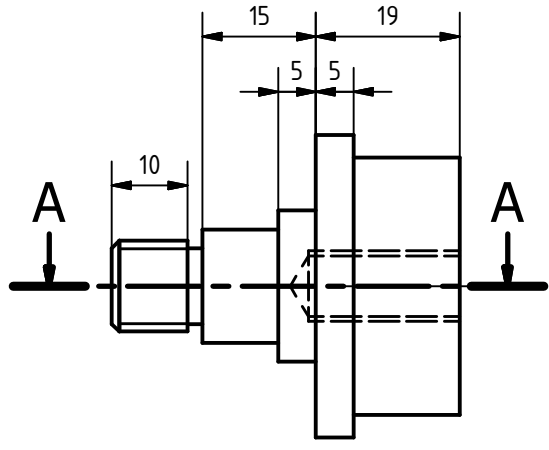
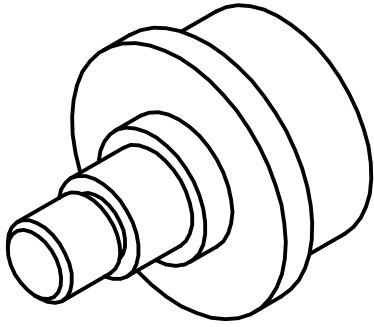

A-A ( 1 : 1 )

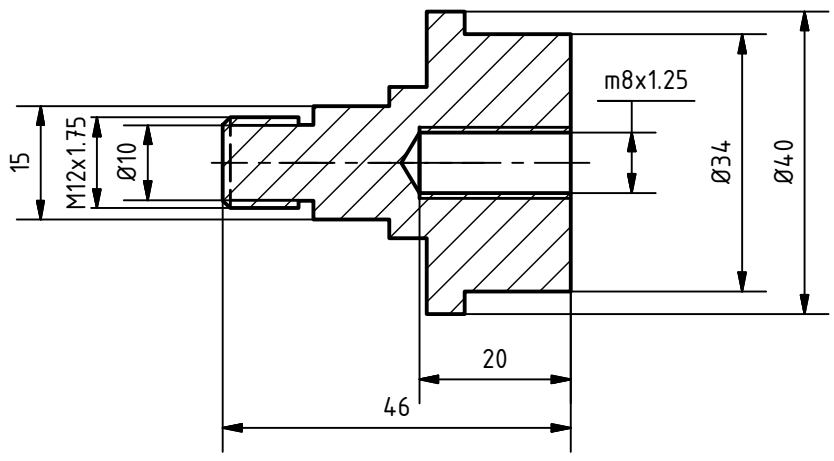

PARTS LIST

ITEM	QTY	PART NUMBER	DESCRIPTION
3.7	1	poros roda gigi	

mesin tanam padi elektrik

Skala :	Digambar	10-10-18	T i m
1 : 1	Diperiksa		
	Waktu		
	Dilihat		

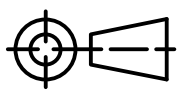

TEKNIK MESIN FT UNY

Kelompok 9

A4

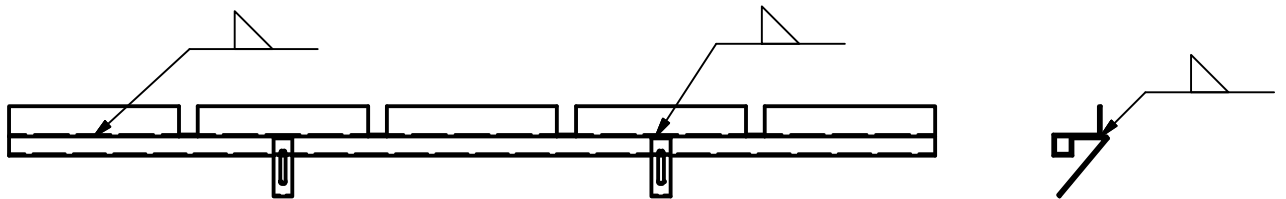
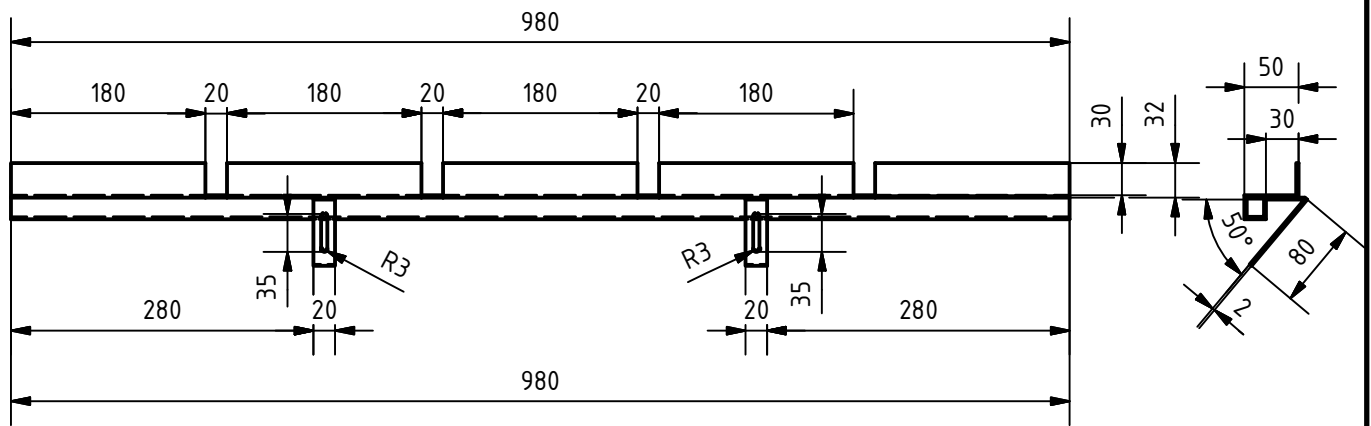
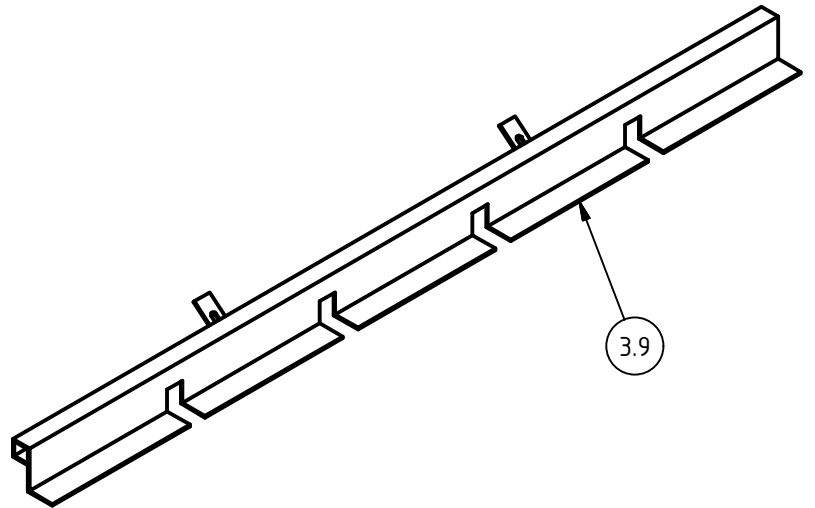

PARTS LIST

ITEM	QTY	PART NUMBER	DESCRIPTION
3.9	1		lintasan meja penampung bibit

meja penampung bibit

Skala :	Digambar	10-10-18	T i m
1 : 8	Diperiksa		
	Waktu		
	Dilihat		

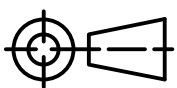

TEKNIK MESIN FT UNY

Kelompok 9

A4

4.

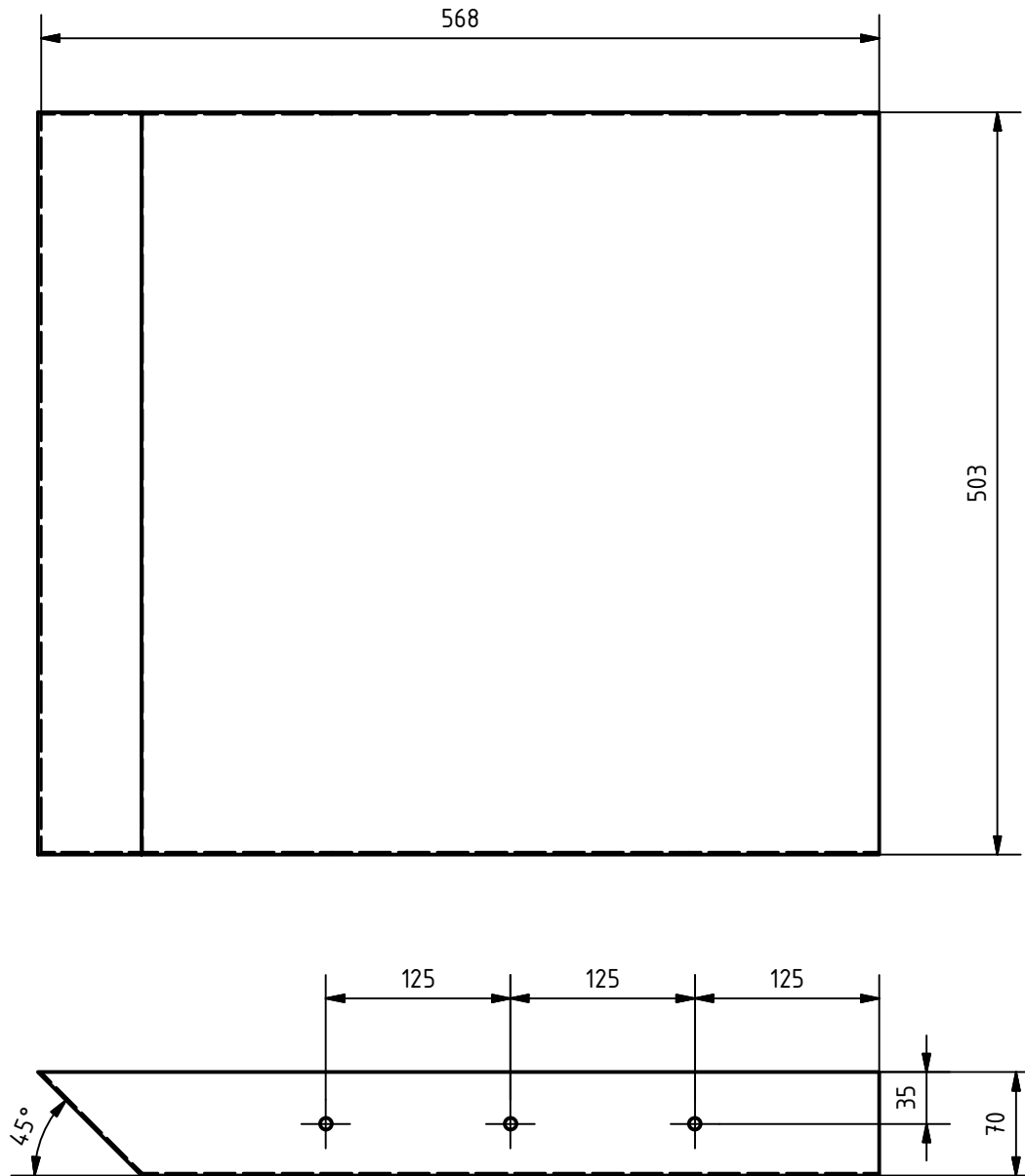

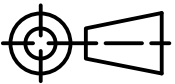
PARTS LIST					
ITEM	QTY	PART NUMBER	DESCRIPTION		
4	1	Pelampung			
Mesin Tanam Padi Elektrik			Skala :		
			1 : 8		
			Digambar	10-10-18	T i m
			Diperiksa		
			Waktu		
			Dilihat		
		TEKNIK MESIN FT UNY	Kelompok 9	A4	

5.

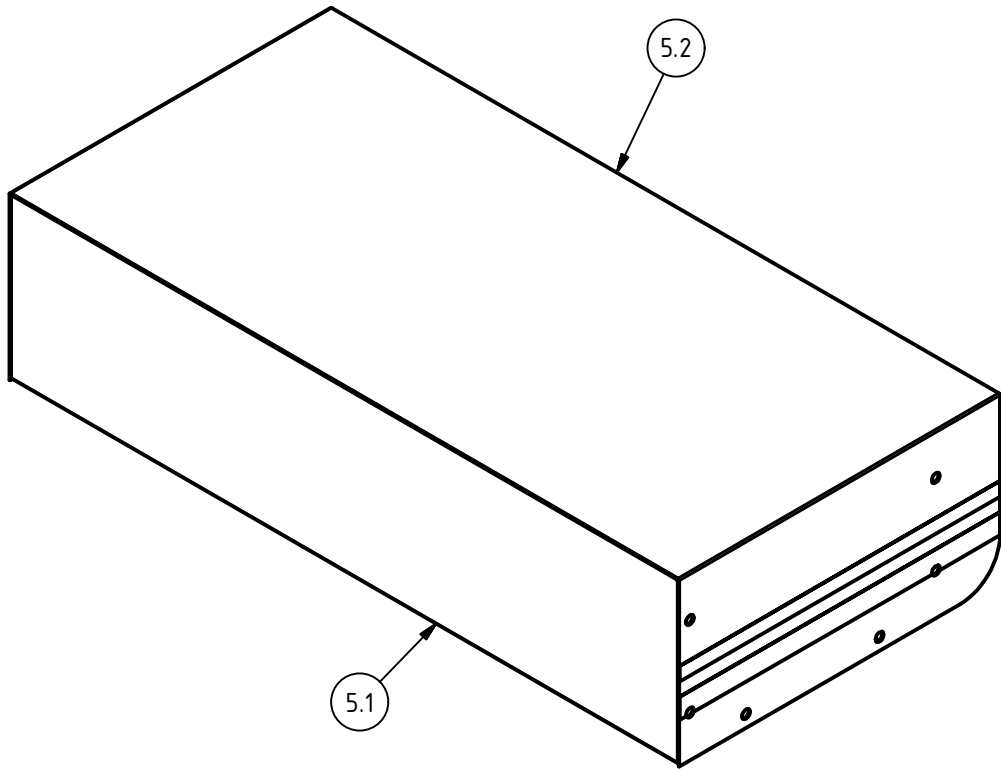

PARTS LIST

ITEM	QTY	PART NUMBER	DESCRIPTION
5.1	1	Alas Kotak Panel	
5.2	1	Tutup Kotak Panel	

Mesin Tanam Padi Elektrik

Skala :	Digambar		Tim
1 : 4	Diperiksa		
	Waktu		
	Dilihat		

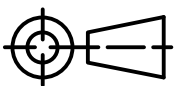

TEKNIK MESIN FT UNY

Kelompok 9

A4

5.1

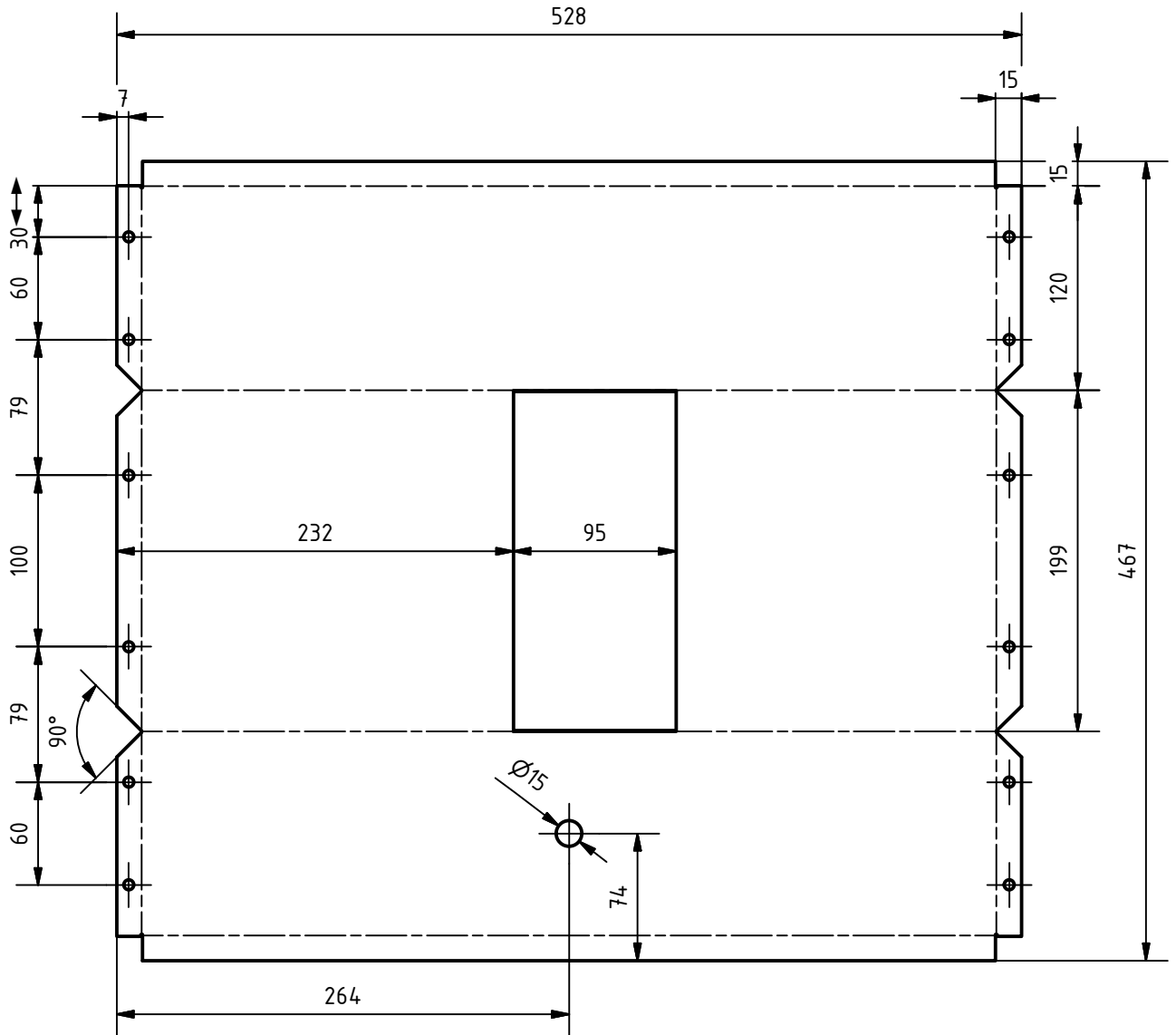
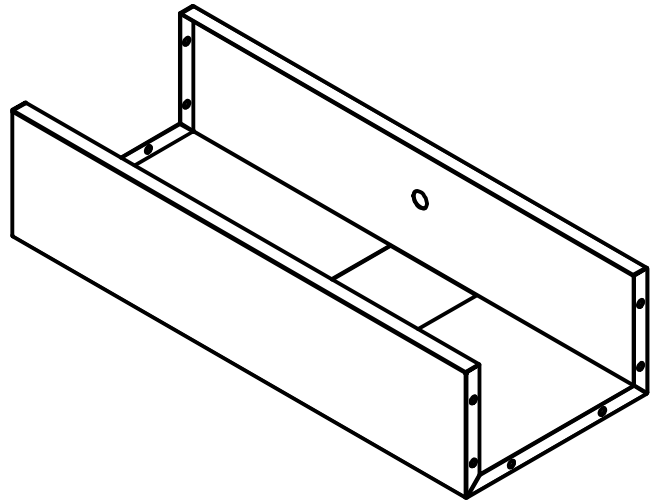

PARTS LIST

ITEM	QTY	PART NUMBER	DESCRIPTION
5.1	1	Alas Kotak Panel	

<h2>Mesin Tanam Padi Elektrik</h2>	Skala :	Digambar		Tim
	1 : 4	Diperiksa		
		Waktu		
		Dilihat		

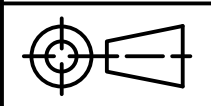

TEKNIK MESIN FT UNY

Kelompok 9

A4

5.2

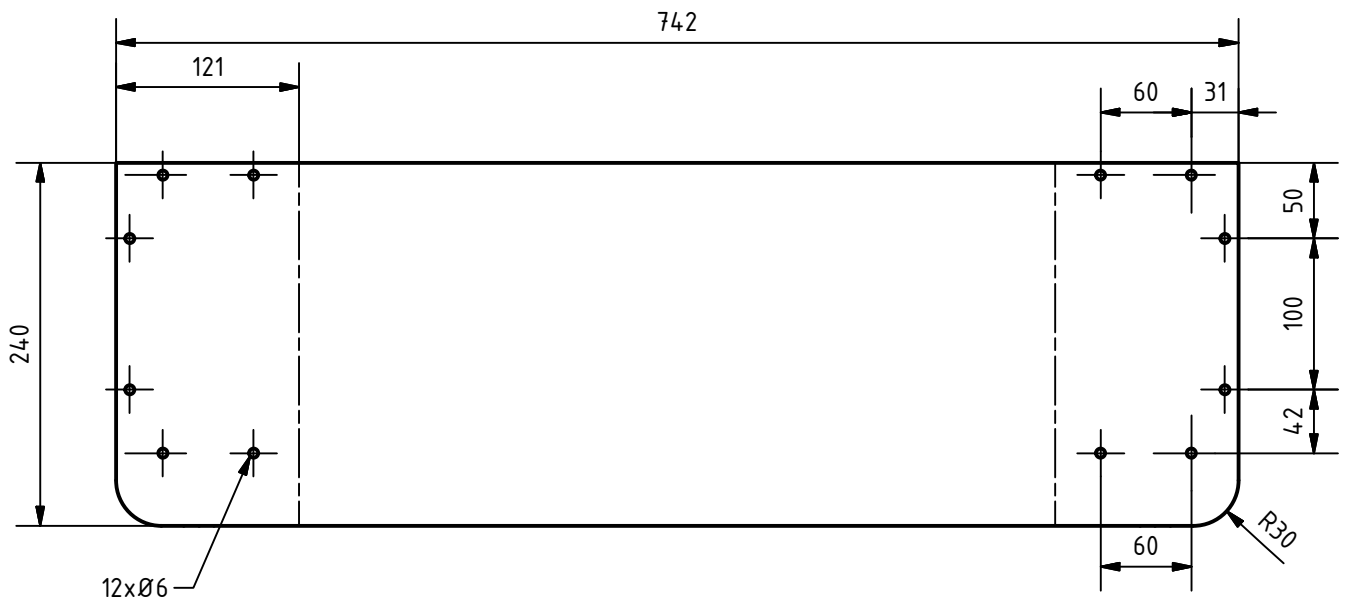
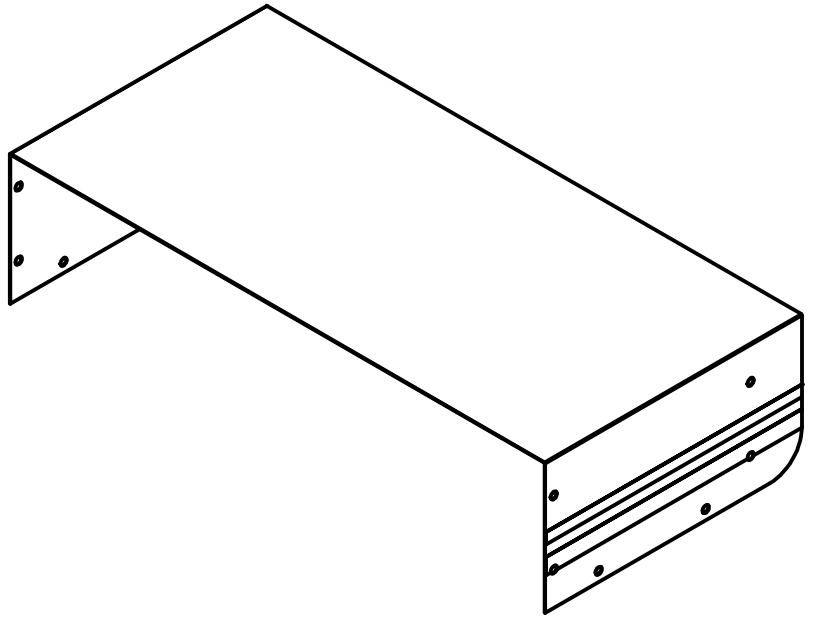

PARTS LIST			
ITEM	QTY	PART NUMBER	DESCRIPTION
5.2	1	Tutup Kotak Panel	
Mesin Tanam Padi Elektrik			Skala :
			1 : 3
TEKNIK MESIN FT UNY		Kelompok 9	
		A4	

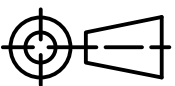

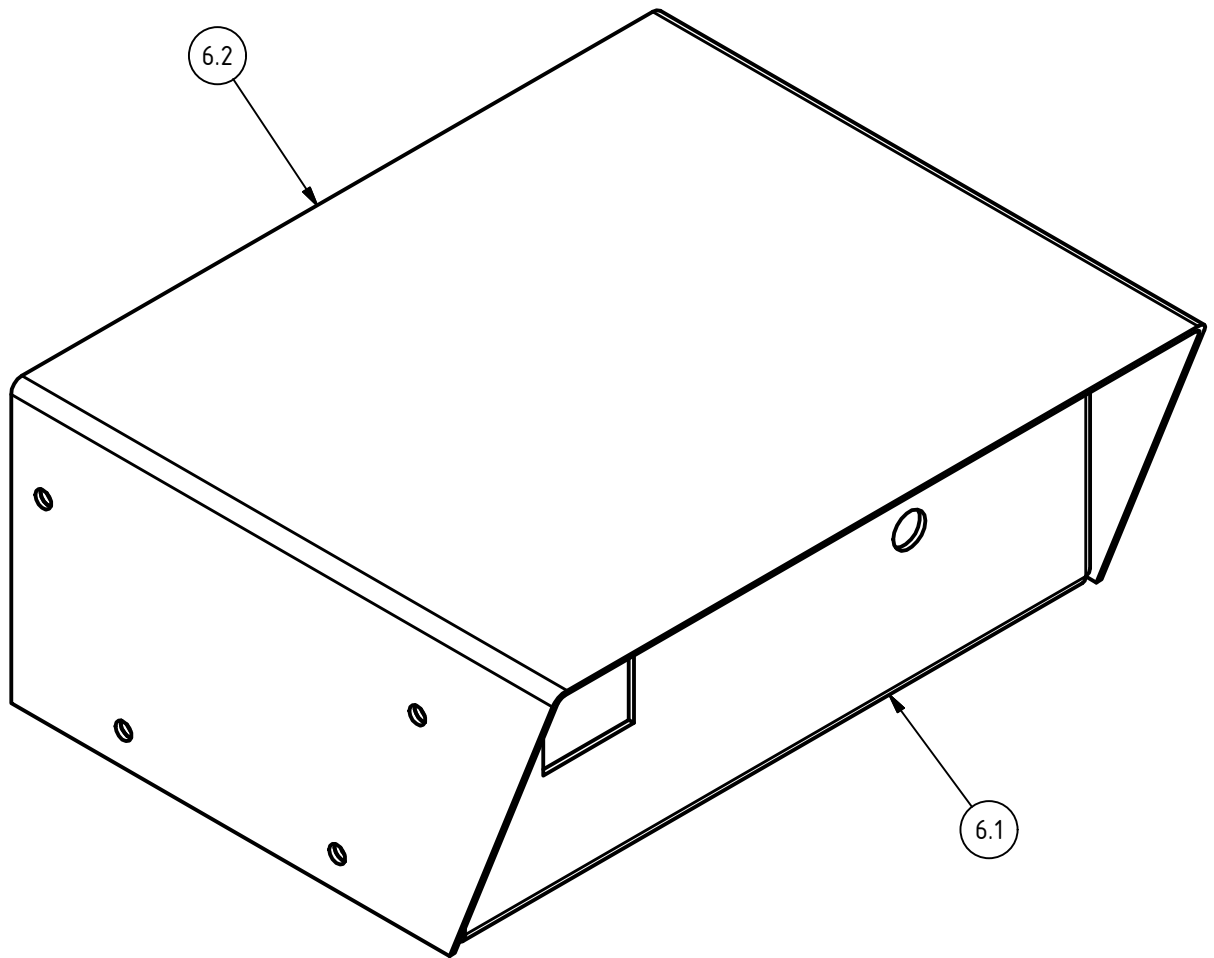

PARTS LIST

ITEM	QTY	PART NUMBER	DESCRIPTION
6.1	1	Alas Control Panel	
6.2	1	Tutup Control Panel	

Mesin Tanam Padi Elektrik

Skala :	Digambar	10-10-18	T i m
1 : 1	Diperiksa		
	Waktu		
	Dilihat		

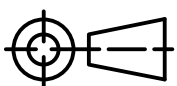

TEKNIK MESIN FT UNY

Kelompok 9

A4

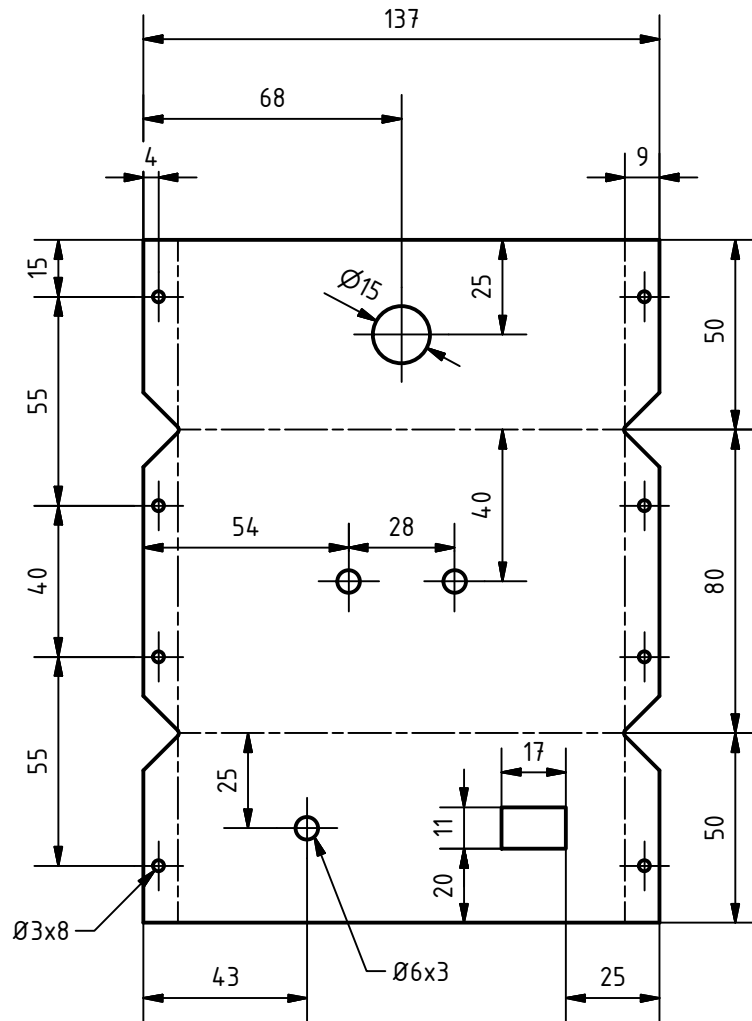
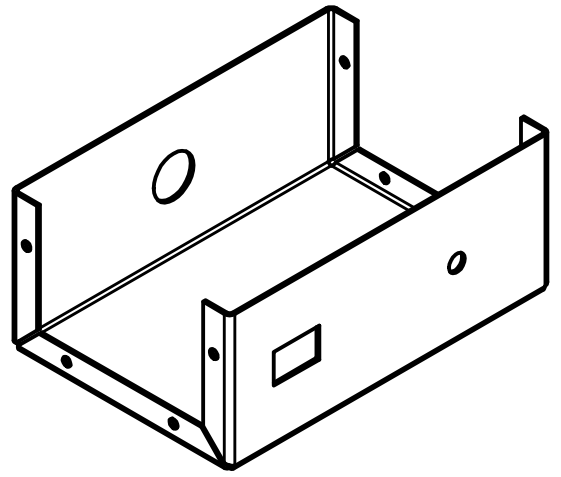

PARTS LIST

ITEM	QTY	PART NUMBER	DESCRIPTION
6.1	1	Alas Control Panel	

Mesin Tanam Padi Elektrik

Skala :	Digambar		Tim
	1 : 2	Diperiksa	
		Waktu	
		Dilihat	

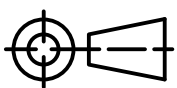

TEKNIK MESIN FT UNY

Kelompok 9

A4



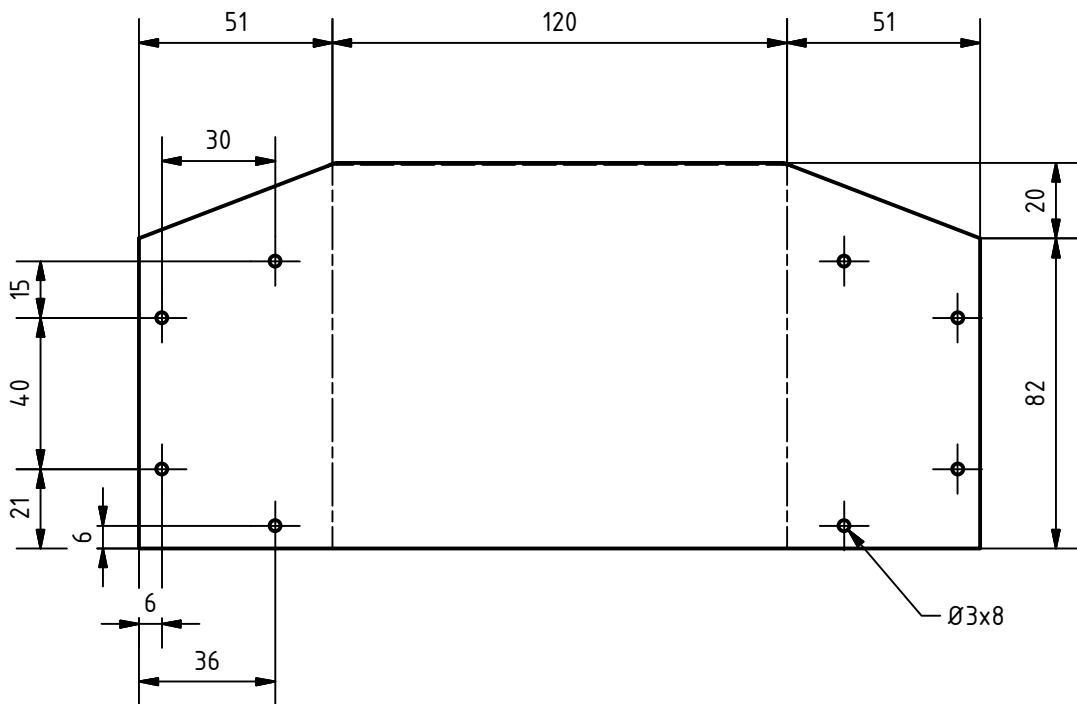
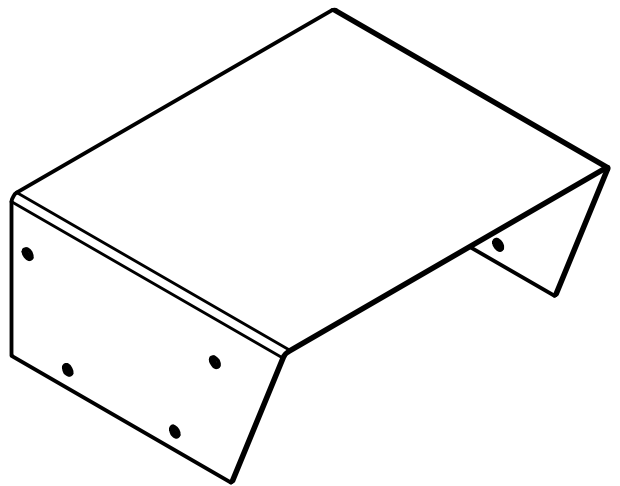

PARTS LIST

ITEM	QTY	PART NUMBER	DESCRIPTION
6.2	1	Tutup Control Panel	

Mesin Tanam Padi Elektrik

Skala :	Digambar	10-10-18	T i m
1 : 2	Diperiksa		
	Waktu		
	Dilihat		

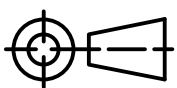

TEKNIK MESIN FT UNY

Kelompok 9

A4

7

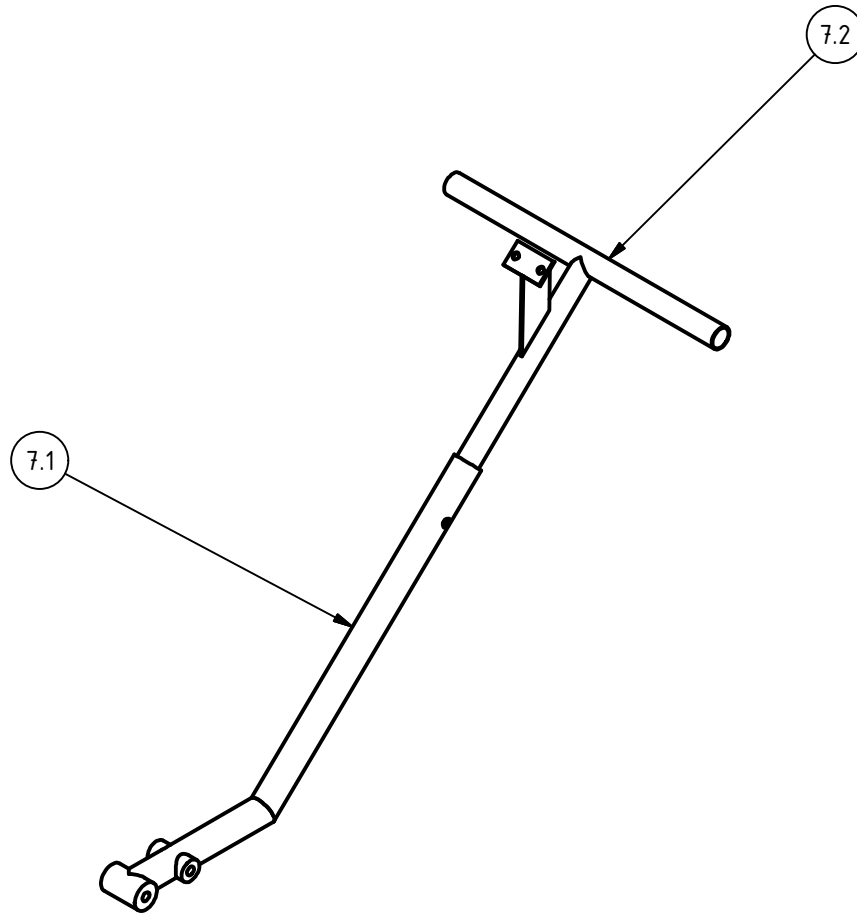

PARTS LIST

ITEM	QTY	PART NUMBER	DESCRIPTION
7.2	1	Handle atas	
7.1	1	handle bawah	

Handle

Skala :	Digambar	10-10-18	T i m
1 : 8	Diperiksa		
	Waktu		
	Dilihat		

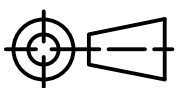

TEKNIK MESIN FT UNY

Kelompok 9

A4

7

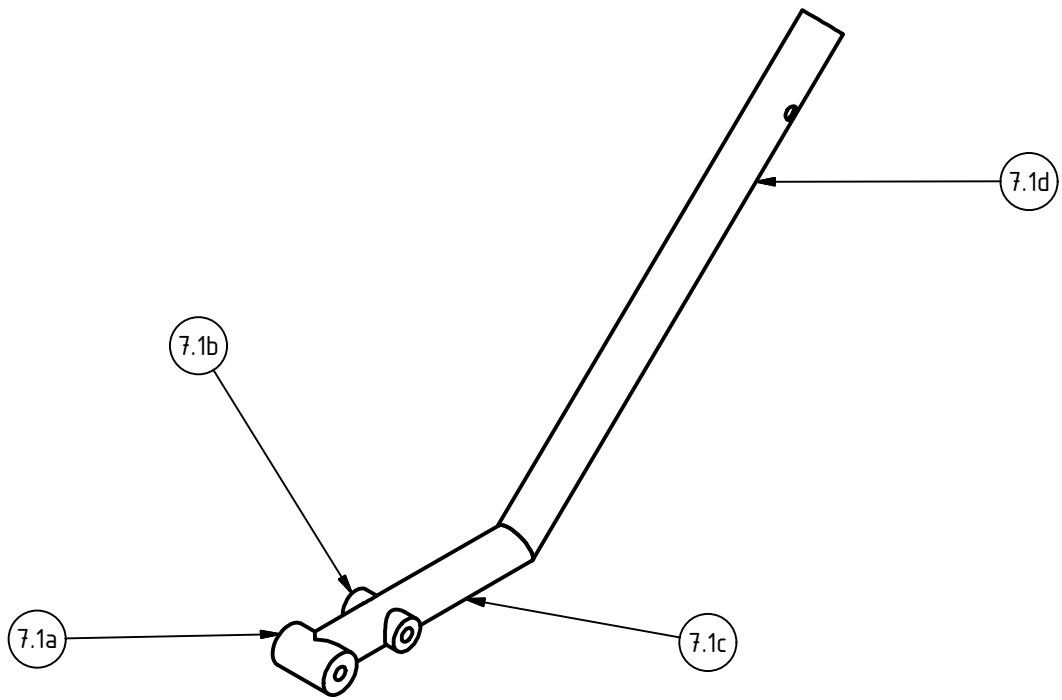

PARTS LIST

ITEM	QTY	PART NUMBER	DESCRIPTION
7.1	1	Handle bawah	

Handle	Skala :	Digambar	10-10-18	T i m
	1 : 4	Diperiksa		
		Waktu		
		Dilihat		

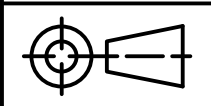

TEKNIK MESIN FT UNY

Kelompok 9

A4

7

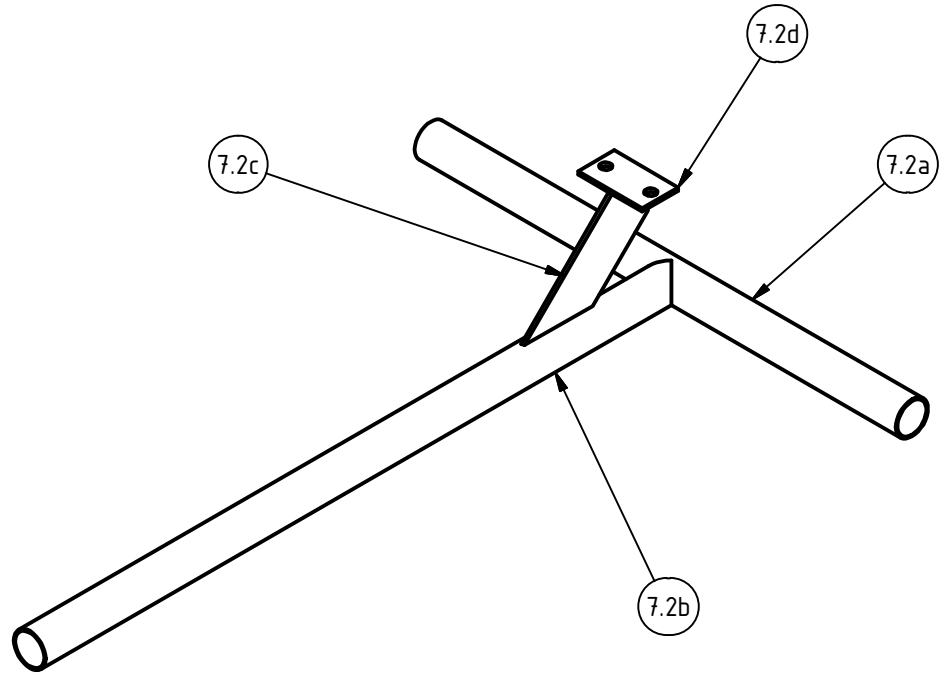

PARTS LIST

ITEM	QTY	PART NUMBER	DESCRIPTION
7.2	1	Handle atas	

Handle	Skala :	Digambar	10-10-18	T i m
	0.3 : 1	Diperiksa		
		Waktu		
		Dilihat		

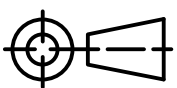

TEKNIK MESIN FT UNY

Kelompok 9

A4

7

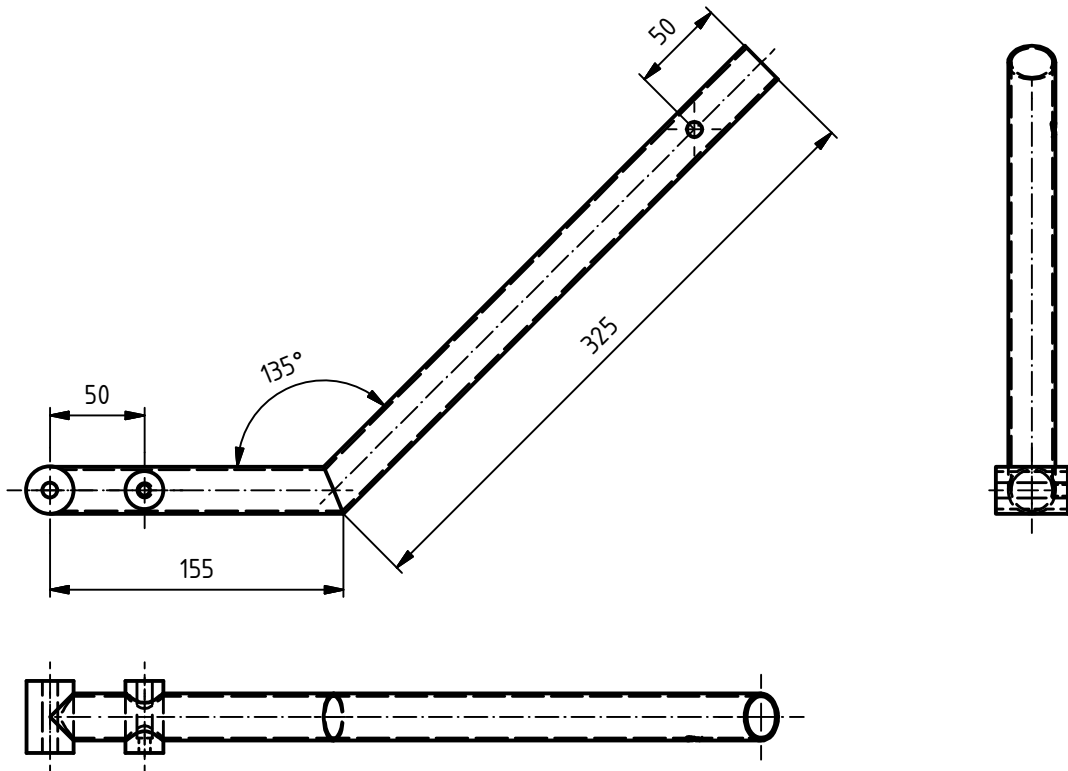
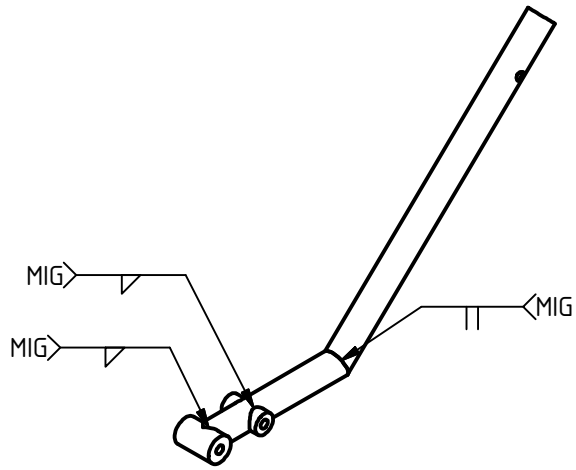

PARTS LIST

ITEM	QTY	PART NUMBER	DESCRIPTION
7.1	1	Handle bawah	

Handle	Skala :	Digambar	10-10-18	T i m
	1 : 4	Diperiksa		
		Waktu		
		Dilihat		

7

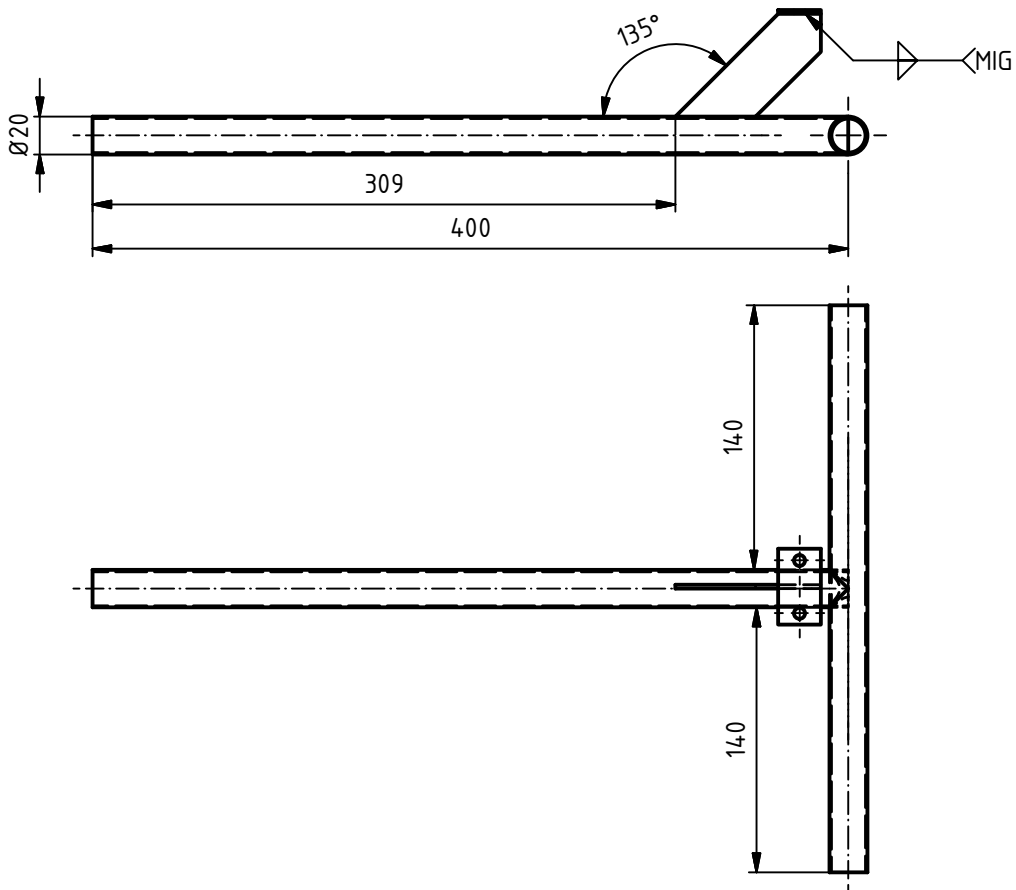
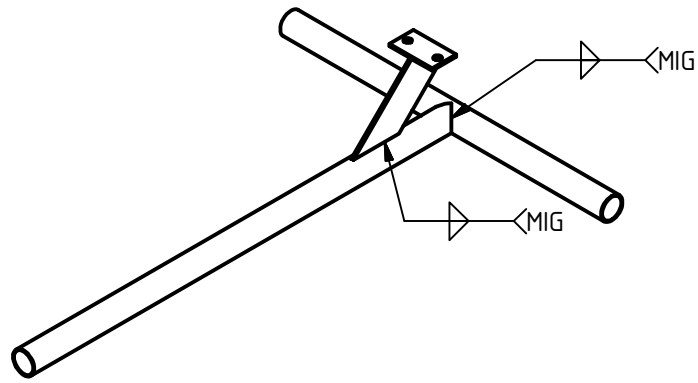

PARTS LIST

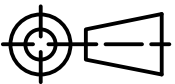
ITEM	QTY	PART NUMBER	DESCRIPTION			
7.2	1	Handle atas				
Handle			Skala :	Digambar	10-10-18	T i m
			0.3 : 1	Diperiksa		
				Waktu		
				Dilihat		
 TEKNIK MESIN FT UNY			Kelompok 9		A4	

7.1a

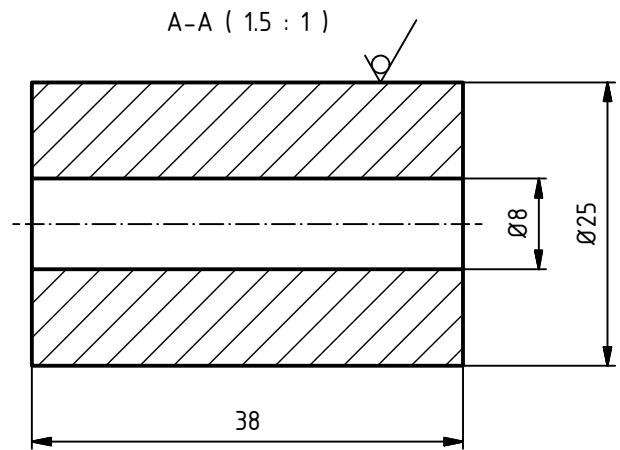
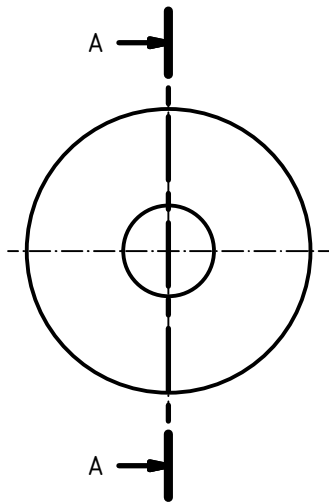

7.1b

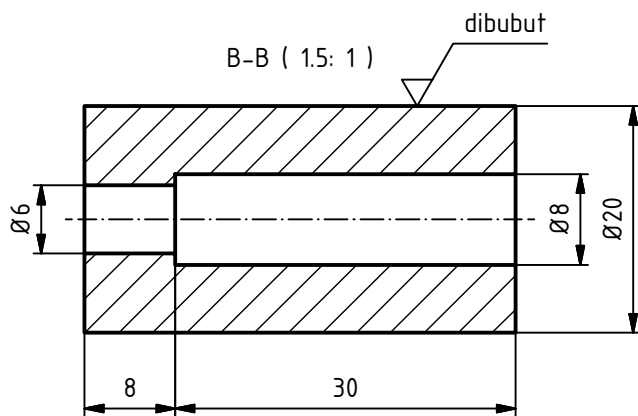
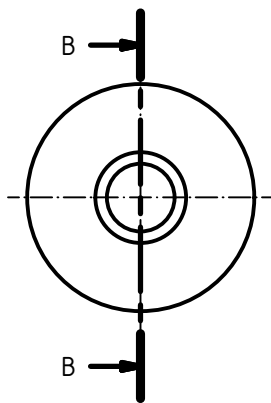

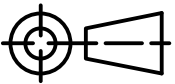
PARTS LIST			
ITEM	QTY	PART NUMBER	DESCRIPTION
7.1	1	Handle bawah	
Handle		Skala :	Digambar 10-10-18 Tim
		1.5 : 1	Diperiksa
			Waktu
			Dilihat
 TEKNIK MESIN FT UNY		Kelompok 9 A4	

7.1c skala 1:2

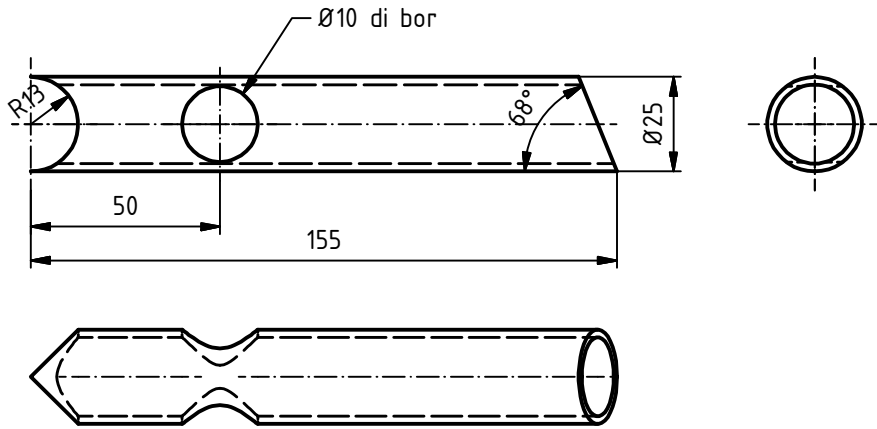

7.1d skala 1:3

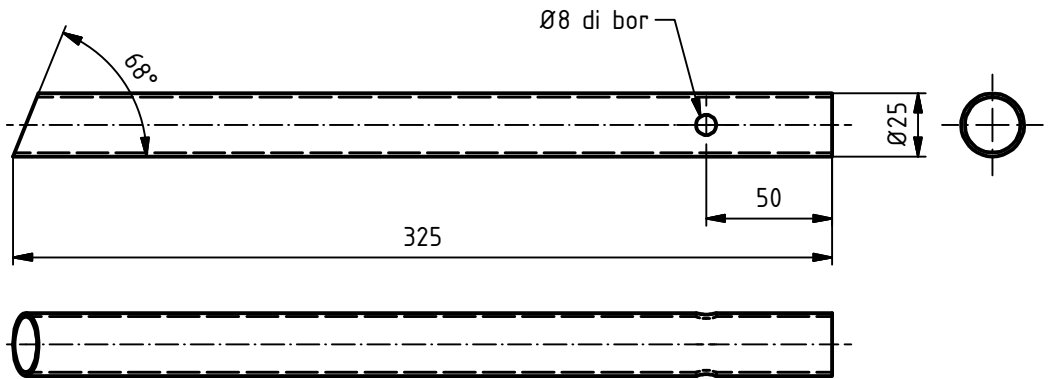

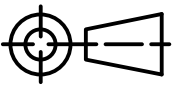
PARTS LIST						
ITEM	QTY	PART NUMBER	DESCRIPTION			
7.1	1	Handle bawah				
Handle			Skala :	Digambar	10-10-18	T i m
			on part	Diperiksa		
				Waktu		
				Dilihat		
		TEKNIK MESIN FT UNY		Kelompok 9	A4	



7.2a

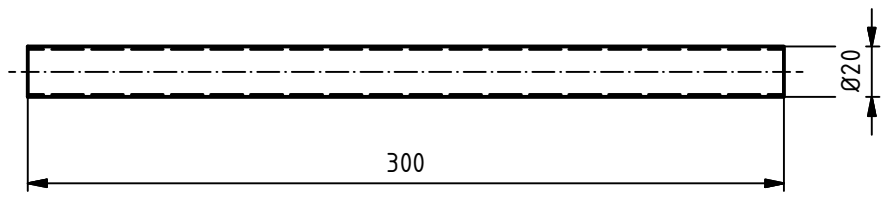

7.2b

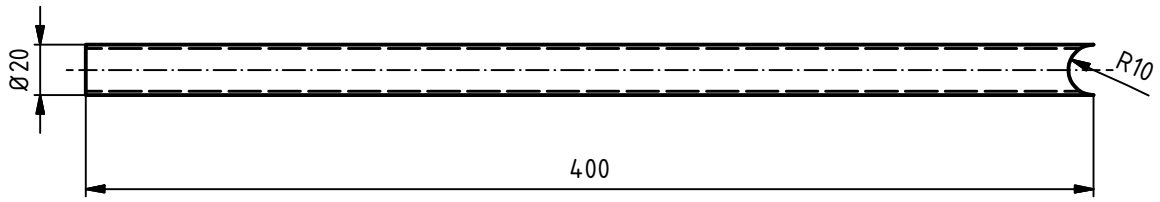

7.2d

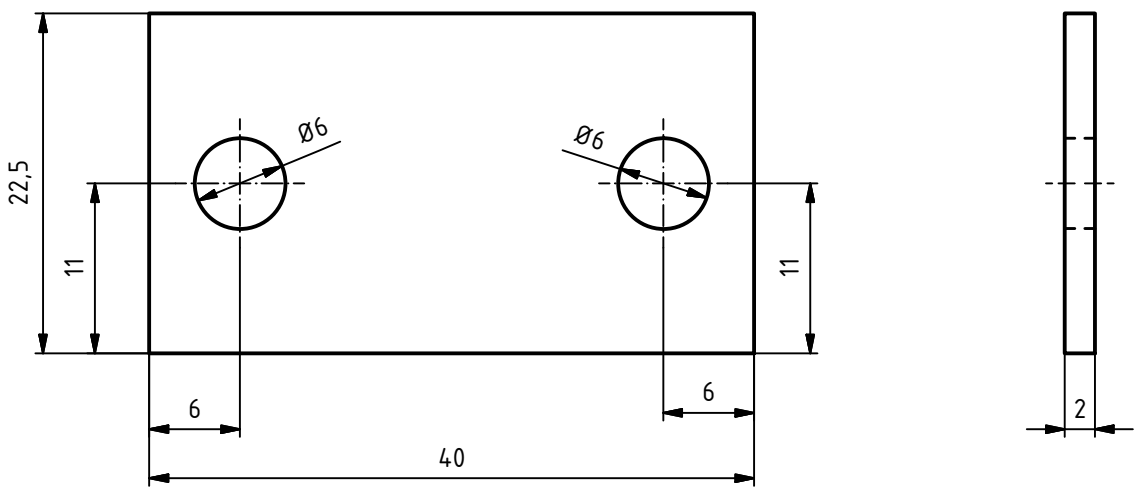

7.2c

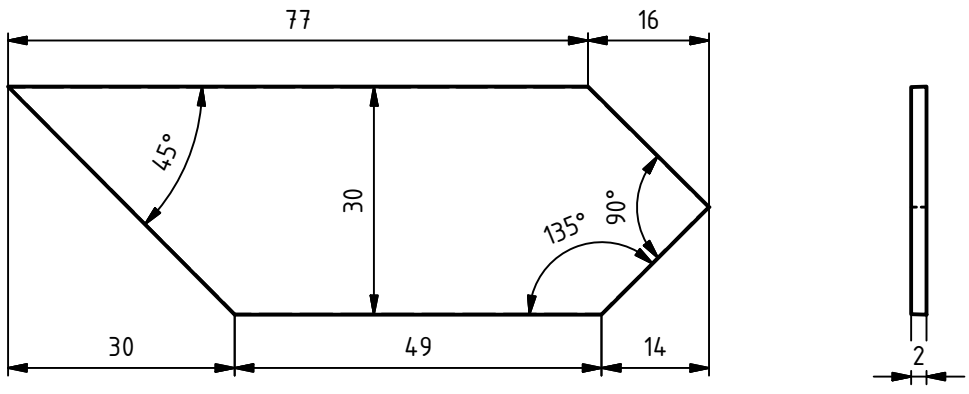

PARTS LIST

ITEM	QTY	PART NUMBER	DESCRIPTION
7.1	1	Upper Handle	

Upper Handle	Skala :	Digambar	10-10-18	T i m
	1:3	Diperiksa		
		Waktu		
		Dilihat		

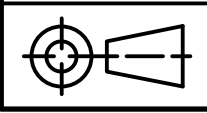

TEKNIK MESIN FT UNY

Kelompok 9



A4

Lampiran 2. Dokumentasi kegiatan

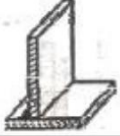
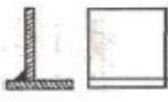
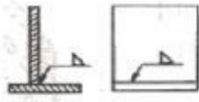
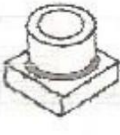
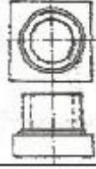
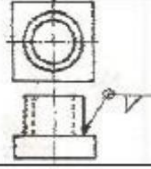

Lampiran 3. Simbol pengelasan

Contoh-contoh penggunaan simbol pengelasan

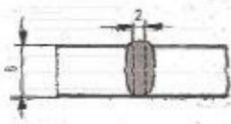
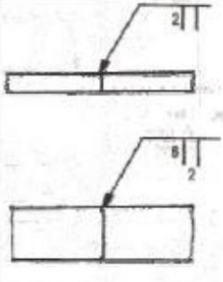
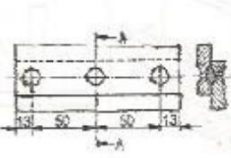
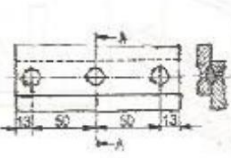
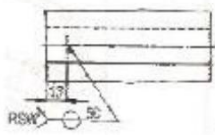
No.	Simbol / jenis pengelasan	Gambar sebenarnya	Gambar pandangan	Penunjukan simbol
1	 Las sudut			
				
2	 Las I			
3	Las titik dengan proses pengelasan Resistance Spot Weld (RSW)			



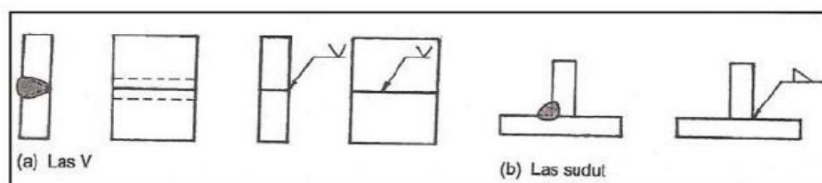

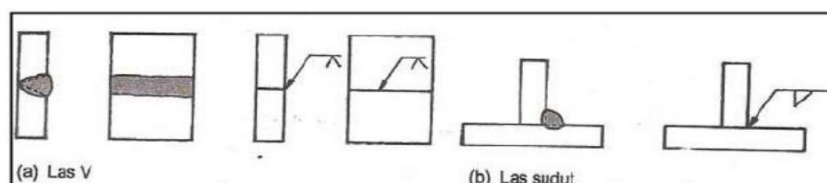

Penunjukan simbol dasar pengelasan sisi jauh (eropa)

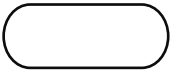
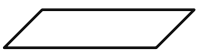

Penunjukan simbol dasar pengelasan sisi dekat (amerika)

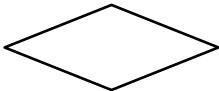

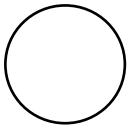
## Lampiran 4. Diagram alir

Lambang	Nama	keterangan
	Terminal	Untuk menyatakan mulai (start), berakhir (end) atau berhenti (stop).
	Input	Data dan persyaratan yang diberikan disusun disini
	Pekerjaan orang	Di sini diperlukan pertimbangan-petimbangan seperti pemilihan persyaratan kerja, persyaratan pengerjaan, bahan dan perlakuan panas, penggunaan faktor keamanan dan factor-faktor lain, harga-harga empiris, dll.
	Pengolahan	Pengolahan dilakukan secara mekanis dengan menggunakan persamaan, tabel dan gambar.
	Keputusan	Harga yang dihitung dibandingkan dengan harga Patokan, dll. Untuk mengambil keputusan.
	Dokumen	Hasil perhitungan yang utama dikeluarkan pada alat ini.
	Penghubung	Untuk menyatakan pengeluaran dari tempat keputusan ke tempat sebelumnya atau berikutnya, atau suatu pemasukan ke dalam aliran yang berlanjut.
	Garis aliran	Untuk menghubungkan langkah-langkah yang berurutan.

Lampiran 5. Tabel Ketentuan umum penyetelan besaran arus dan tegangan berdasarkan diameter kawat elektroda

Diameter kawat	Arus ( amper )	Tegangan ( volt )	Tebal bahan
0,6 mm	50 – 80	13 – 14	0,5 – 1,0 mm
0,8 mm	60 – 150	14 – 22	0,8 – 2,0 mm
0,9 mm	70 – 220	15 – 25	1,0 – 10 mm
1,0 mm	100 – 290	16 – 29	3,0 – 12 mm
1,2 mm	120 – 350	18 – 32	6,0 – 25 mm
1,6 mm	160 – 390	18 – 34	12,0 – 50 mm

Komposisi kimia untuk elektroda karbon steel

AWS CLASS	CARBON	MANGAN	SILICON	SULFUR	PHOS	MOLYB	OTHER
ER70S-2	0.07	0.90-1.40	0.40-0.70	0.035	0.025		0.05-0.15 Ti
							0.02-0.12 Zr
							0.05-0.15 Al
ER70S-3	0.06-0.15	0.90-1.40	0.45-0.75	0.035	0.025		
ER70S-4	0.07-0.15	1.00-1.50	0.65-0.85	0.035	0.025		
ER70S-5	0.07-0.19	0.90-1.40	0.30-0.60	0.035	0.025		0.50-0.90 Al
ER70S-6	0.07-0.15	1.40-1.8	0.80-1.15	0.035	0.025		
ER70S-7	0.07-0.15	1.50-2.00	0.50-0.80	0.035	0.025		
ERSOS-D2	0.07-0.12	1.60-2.10	0.50-0.80	0.035	0.025	0.40-0.60	
ER70S-G	NOT SPECIFIED						

## Lampiran 6. brosur

### 5. Kelebihan Alat

- Lebih mudah dipersiapkan dibandingkan dengan alat yang sudah ada.
- Harga lebih terjangkau.
- Bahan bakar atau sumber tenaga lebih ramah lingkungan.

### 6. Kekurangan Alat

- Tidak bisa bekerja secara maksimal jika lumpur terlalu dalam.
- Penggunaan battery yang terbatas
- Membutuhkan tarikan yang stabil supaya jarak penanaman tetap sama

### 7. Dokumentasi



Alamat: Kampus Karangmalang, Yogyakarta, 55281  
 Telp. (0274) 586168 pos. 276.289.292 (0274) 586734 Fax. (0274) 586734  
 website: <http://fkm.uny.ac.id> e-mail: [fkm@uny.ac.id](mailto:fkm@uny.ac.id); [teknik@uny.ac.id](mailto:teknik@uny.ac.id)

**JURUSAN PENDIDIKAN TEKNIK MESIN  
 FAKULTAS TEKNIK  
 UNIVERSITAS NEGERI YOGYAKARTA**

## MESIN TANAM PADI ELEKTRIK



KARYA TUGAS AKHIR  
 MAHASISWA PRODI DIPLOMA-III TEKNIK MESIN  
 UNIVERSITAS NEGERI YOGYAKARTA  
 ANGGARAN 2016

## Mesin tanam padi elektrik

### 1. Pendahuluan



Perkembangan teknologi di sektor pertanian menuntut petani terus melakukan pembaharuan guna menunjang kebutuhan dan meningkatkan efektifitas dan efisiensi dalam hal menanam bibit padi. dengan hadirnya mesin tanam padi "mesin tanam padi elektrik" mesin tanam padi semi otomatis yang digerakan oleh tenaga listrik diharapkan dapat menjadi solusi dibidang pertanian.

### Spesifikasi mesin tanam padi elektrik:

Dimensi	: 832x500x429 mm
Berat	: 35 kg
Type Mekanis	: Semi otomatis
Penggerak mesin	: Motor DC 12 V
Daya	: 100 W
Battery	: 12 V 9aH
Jumlah alur penanam	: 4
Jarak alur tanam	: 200 mm
Kapasitas kerja	: 120-180 menit/1000m <sup>2</sup>
Umur benih padi	: 15 hari

### 2. Manfaat

membantu petani indonesia untuk meningkatkan produktifitas dan efektifitas dalam hal menanam padi seiring berkurangnya jumlah petani muda saat ini.



### 3. Bibit Padi



jenis bibit padi yang digunakan harus mempunyai kriteria sebagai berikut:

- merupakan jenis padi yang ditanam dengan cara ditanam/disemai di lahan (washed root seedling)/dapog
- bibit padi yang telah berusia 20-25 hari

### 4. Penanaman

- kedalaman lumpur tidak lebih dari 4 cm jika terlalu dalam maka, bibit tidak dapat tertanam dengan sempurna.
- bibit akan tertanam dengan jarak 20 cm berbaris, akan tetapi untuk jarak antar baris di tentukan dengan kecepatan menarik mesin
- kecepatan putar lengan penanam dapat diatur menggunakan controler.
- sebelum bibit terpasang pada seedling try, kecepatan putar dapat disesuaikan dengan kemampuan gerakan saat menarik mesin
- penyulaman dilakukan apabila ada batang padi yang tidak menancap.



## Lampiran 7. banner

**JURUSAN PENDIDIKAN TEKNIK MESIN  
FAKULTAS TEKNIK  
UNIVERSITAS NEGERI  
YOGYAKARTA**



KARYA TUGAS AKHIR MAHASISWA DIPLOMA-III TEKNIK MESIN  
ANGKATAN 2016  
"MESIN TANAM PADI ELEKTRIK "

## "MESIN TANAM PADI ELEKTRIK"

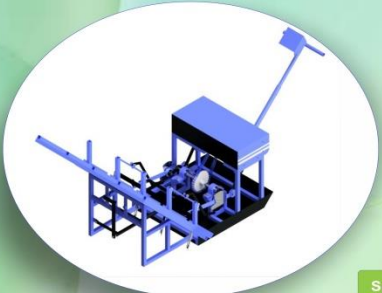

**Spesifikasi Mesin**

SPESIFIKASI MESIN TANAM PADI ELEKTRIK	
DIMENSI	832x500x429 MM
BERAT	35 KG
TIPe MEKANISME	SEMI OTOMATIS
MODEL PENGOPERASIAN	DITARIK
PENGERAK LENGAN TANAM	MOTOR DC 12V
DAYA	100 W
KECEPATAN	70 RPM
BATTERY	12V 9AH
JUMLAH ALUR TANAM	4
JARAK ALUR TANAM	20 CM
KAPASITAS KERJA	120-180 HENIT/1000 M <sup>2</sup>
UMUR BENIH PADI	15 HARI

**Cara Kerja**

Mesin tanam padi ini termasuk mesin semi otomatis, dimana sistem penggerak hanya menggerakkan komponen lengan penanam, pengoperasian mesin ini dilakukan dengan cara di tuntun (*walking type*).  
Jumlah jalur tanam sebanyak 4 jalur dengan jarak tetap 20 cm.  
Mesin ini memakai jenis bibit yang ditanam atau disemai di lahan (*washed root seedling*).  
Sumber tenaga mesin ini berasal dari battery dengan kapasitas 12V yang menggerakkan motor DC 12V 100W yang dihubungkan menggunakan rantai untuk menggerakkan poros dan terhubung dengan arm atau lengan.

Alamat : Kampus Karangmalang, Yogyakarta, 55281  
Telp. (0274) 586168 psw. 276,289,292 (0274) 586734 Fax. (0274) 586734  
website : <http://ft.uny.ac.id> e-mail: [ft@uny.ac.id](mailto:ft@uny.ac.id) ; [teknik@uny.ac.id](mailto:teknik@uny.ac.id)

Lampiran 8. poster

## MESIN TANAM PADI ELEKTRIK

### SEBAGAI SOLUSI PENINGKATAN EFEKTIFITAS MENANAM PADI MENUJU ERA PERTANIAN MODERN



#### ABSTRAK

Hingga 30 Juli 2010, jumlah pengadaan beras Bulog sebesar 2.183.069 ton, terdiri dari beras impor dan penyerapan beras petani dalam negeri. Jumlah tersebut jika dikurangi volume impor, beras Bulog yang berasal dari petani hanya 1.317.550 ton. Beranjak dari permasalahan tersebut, maka perlu solusi untuk membuat sebuah alat yang dapat mendukung para petani. Tugas akhir ini bertujuan untuk: (1) merancang dan membuat mesin tanam padi berbasis elektrik (2) meningkatkan efektifitas penanaman padi untuk meningkatkan produktivitas padi. Proses pembuatan mesin elektrik rice transplation machine dikerjakan melalui berbagai tahap, yaitu: (1) identifikasi kebutuhan, (2) analisis kebutuhan, (3) perancangan alat, (4) pembuatan alat, (5) pengujian alat. Komponen dari mesin tanam padi elektrik ini terdiri dari rangka, arm planting, seedling tray, motor DC 12V 100 Watt, controller PWM, battery 12 V. Hasil dari pengujian menunjukkan elektrik rice transplation machine dapat membantu petani dalam hal meningkatkan efektifitas penanaman padi, dibandingkan dengan cara manual yang membutuhkan banyak tenaga dan menyita waktu.

**Kata kunci:** penanam padi, elektrik

#### PENDAHULUAN

Selain itu, pesatnya laju pertumbuhan penduduk sebesar 1,94% per tahun (lebih dari 237 juta jiwa pada tahun 2010 menurut data BPS) menyebabkan meningkatnya kebutuhan terhadap beras sementara pertumbuhannya tidak sebanding dengan permintaan, bahkan cenderung melandai (levelling Off), hal ini menyebabkan tingginya nilai impor beras di Indonesia. Berdasarkan data Bulog, hingga 30 Juli 2018, jumlah pengadaan beras Bulog sebesar 2.183.069 ton, terdiri dari beras impor dan penyerapan beras petani dalam negeri. Sehingga, jika dikurangi volume impor, beras Bulog yang berasal dari petani hanya 1.317.550 ton. Beranjak dari permasalahan tersebut, maka perlu solusi untuk membuat alat yang dapat membantu para petani untuk dapat bekerja secara lebih efektif. Maka melalui alat Elektrik Rice Transplation Machine dapat memberikan solusi bagi para petani supaya lebih produktif.

#### RUMUSAN MASALAH

Berdasarkan latar belakang di atas, disampaikan rumusan masalah sebagai berikut:  
 1) Bagaimana rancangan alat Elektrik Rice Transplation Machine sebagai solusi peningkatan efektifitas menanam padi menuju era pertanian modern  
 2) Bagaimana prinsip kerja Elektrik Rice Transplation Machine sebagai solusi peningkatan efektifitas menanam padi menuju era pertanian modern

#### METODE PENGEMBANGAN

```

        graph TD
            A([MULAI]) --> B[ANALISIS KEBUTUHAN]
            B --> C{DESIGN}
            C -- NO --> B
            C -- PERBAIKI --> B
            C -- YES --> D[DEVELOPMENT]
            D --> E[IMPLEMENTATION]
            E --> F[EVALUATION]
            F -- NO --> C
            F -- YES --> G([SELESAI])
        
```

#### HASIL

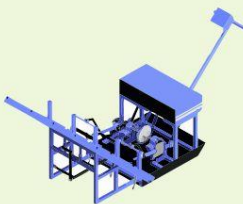

SPESIFIKASI ELEKTRIK RICE TRANSPLATION MACHINE	
DIMENSI	B30x500x429 MM
BERAT	35 kg
TIPE MEKANIK	SEMI OTOMATIS
MODEL PENGOPERASIAN	DITARIK
PENGGERAK LENGAN TANAM	MOTOR DC 12V
DAYA	100 W
KECEPATAN	70 RPM
BATTERY	12V 9AH
JUMLAH ALUR TANAM	4
KAPASITAS KERJA	120-180 HENIT/1000m <sup>2</sup>
UMUR BIBIT PADI	MIN 15 HARI

#### KESIMPULAN

elektrik rice transplation machine dalam penerapannya sangat membantu petani karena dapat menyingkat waktu proses penanaman bibit padi, jika dilakukan dengan cara manual petani memerlukan banyak tenaga untuk menyelesaikan penanaman bibit, jika pun dilakukan sendiri juga memerlukan waktu yang lama, maka dengan adanya alat ini petani bisa menyingkat waktu penanaman dan biaya atau upah penanaman bibit padi.

#### SARAN

adapun saran dari penulis untuk pengembangan elektrik rice transplation machine kedepan yaitu:

- gunakan material yang tidak terlalu lentur pada bagian lengan arm, karena jika terlalu lentur dapat menghambat jalanya mesin.
- menambahkan fasilitas panel surya sebagai sumber tenaga listrik.



PRODI DIPLOMA-III ANGKATAN 2016  
 JURUSAN PENDIDIKAN TEKNIK MESIN  
 FAKULTAS TEKNIK  
 UNIVERSITAS NEGERI YOGYAKARTA



Lampiran . Kartu Bimbingan







**UNIVERSITAS NEGERI YOGYAKARTA**  
**FAKULTAS TEKNIK**  
**JURUSAN PENDIDIKAN TEKNIK MESIN**

**KARTU BIMBINGAN PROYEK AKHIR**

Judul Proyek Akhir : PROSES PEMBUATAN RANGKA PADA MESIN TANAM  
PADI ELEKTRIK  
Nama : Achmad Safii  
No. Mahasiswa : 16508134021  
Dosen Pembimbing : Drs. Bambang Setiyo Hari Purwoko, M.Pd.

Bimb. ke	Hari/Tanggal	Materi Bimbingan	Catatan Dosen Pembimbing	Tanda Tangan Dosen Pembimbing
1	3 / g 2018	Konsultasi Judul Karya teknologi		
2	10 / g 2018	Bimbingan Proposal		
3	10 / 12 2018	Konsultasi Judul laporan		
4	14 / 01 2019	Monitoring dan uji kinerja alat		
5	17 / 01 2019	Bimbingan laporan	- Perbaiki Pernusan Masalah	

6	11/02 2019	Bimbingan Laporan	- Perbaiki Flow chart	
7	24/02 2019	Bimbingan Laporan	- Tambahkan detail Pengelasan	
8	28/02 2019	Bimbingan Laporan Tata tulis		
9	4/03 2019	Bimbingan bab V kesimpulan	Samakan dengan rumusan Masalah	
10		OK! Setuju ujian		
11				

Yogyakarta, 5-03-2019

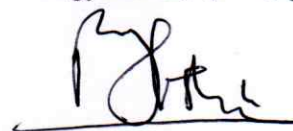

Drs. Bambang Setiyo Hari Purwoko, M.Pd.  
NIP. 195710061988121001